

Programmable Gain Element Using the **AD5426/AD5432/AD5443** Current Output DACs

CIRCUIT FUNCTION AND BENEFITS

This circuit provides a programmable gain function using a multiplying digital-to-analog converter (DAC) and an operational amplifier (op amp). The maximum gain value and the

temperature coefficient (TC) are set by the external resistors and the resolution of the programmable gain is set by the resolution of the DAC.

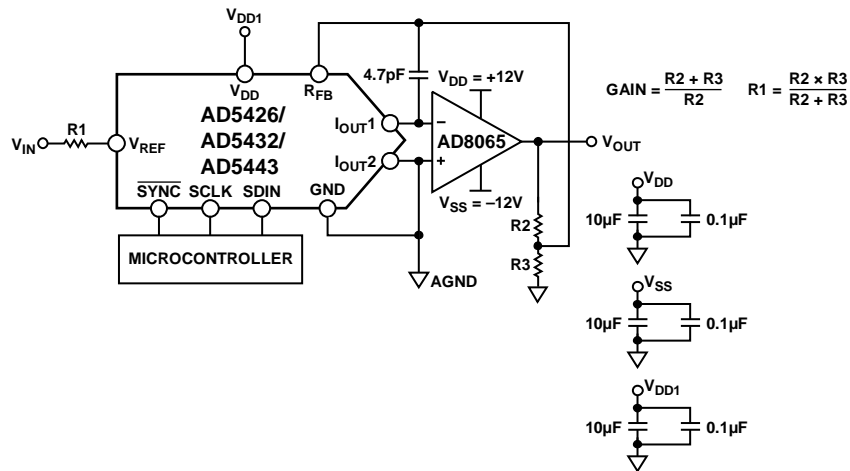

Figure 1. Programmable Gain Circuit Using a Current Output DAC (Simplified Schematic)

08272-001

TABLE OF CONTENTS

Circuit Function and Benefits.....	1	Common Variations.....	3
Revision History	2	References.....	3
Circuit Description.....	3		

REVISION HISTORY

11/2017—Rev. A to Rev. B

Document Title Changed from CN0038 to AN-1498..... Universal
Changes to Circuit Description Section and Common
Variations Section..... 3

7/2009—Rev. 0 to Rev. A

Updated Format..... Universal

7/2009—Revision 0: Initial Version

CIRCUIT DESCRIPTION

The circuit shown in Figure 1 is the recommended method for increasing the gain of the circuit. The R1, R2, and R3 resistors must have similar temperature coefficients (TCs), but they do not need to match the temperature coefficients of the DAC. This approach is recommended in circuits where gains of greater than 1 are required.

The gain is calculated with the following equation:

$$V_{OUT} = -Gain \times V_{IN} \times (D/2^N)$$

where:

D is the digital word loaded to the DAC and N is the number of bits: $D = 0$ to 255 (8-bit [AD5426](#)); $D = 0$ to 1023 (10-bit [AD5432](#)); and $D = 0$ to 4095 (12-bit [AD5443](#)).

V_{OUT} is the output voltage.

V_{IN} is the input voltage.

The benefit of this circuit is its ability to overcome gain TC errors using resistor matching. The TCs of the external resistors must match each other, but do not need to match the DAC internal ladder resistance.

Resistor R1 is required because R1 plus the input impedance of the DAC must equal the total feedback resistance, which is $R_{FB} + R2 || R3$. The input impedance of the DAC is R_{FB} , therefore

$$R1 + R_{FB} = R_{FB} + R2 || R3$$

$$R1 = R2 || R3$$

The values of the R1 and R2 resistors must be chosen so the output voltage does not exceed the output range of the op amp for the given supply voltage. The bias current of the op amp is multiplied by the total feedback resistance ($R_{FB} + R2 || R3$) to give an associated offset. Therefore, the values of R1 and R2 cannot be too large or they have a significant effect on the overall output offset voltage.

The input offset voltage of an op amp is multiplied by the variable gain (due to the code dependent output resistance of the DAC) of the circuit. A change in this noise gain between two adjacent digital fractions produces a step change in the output voltage due to the input offset voltage of the amplifier. This output voltage change is superimposed on the desired change in output between the two codes and gives rise to a differential linearity error that, if large enough, can cause the DAC to be nonmonotonic. The [AD8065](#) benefits from a low input offset voltage and low input bias currents to overcome this issue.

COMMON VARIATIONS

The [OP1177](#) is another op amp for the current to voltage (I to V) conversion circuit. It also provides a low input offset voltage and ultralow input bias current. For the selection of the reference, the input voltage is restricted by the rail-to-rail voltage of the op amp selected and the gain set up by Resistors R2 and R3.

REFERENCES

[ADIsimPower Design Tool](#). Analog Devices, Inc.

Kester, Walt. 2005. Chapter 3 and Chapter 7, *The Data Conversion Handbook*. Analog Devices.

MT-015 Tutorial. *Basic DAC Architectures II: Binary DACs*. Analog Devices.

MT-031 Tutorial. *Grounding Data Converters and Solving the Mystery of "AGND" and "DGND"*. Analog Devices.

MT-033 Tutorial, *Voltage Feedback Op Amp Gain and Bandwidth*. Analog Devices.

MT-035 Tutorial. *Op Amp Inputs, Outputs, Single-Supply, and Rail-to-Rail Issues*. Analog Devices.

MT-101 Tutorial. *Decoupling Techniques*. Analog Devices.

[Voltage Reference Wizard Design Tool](#). Analog Devices.