

ONET1131EC Externally Modulated Laser Driver With Integrated Clock and Data Recovery (CDR)

1 Features

- Modulator Driver with Minimum Output Amplitude up to 2 V_{pp} Single-Ended and Bias Current up to 150 mA Source
- Supports Externally Modulated Lasers Including the Electro-Absorption Modulator Lasers (EML) and the Mach-Zahnder Modulator (MZM) Based lasers
- Integrated CDR with 9.80 – 11.7 Gbps Reference-Free Operation
- Two-Wire Digital Interface with Integrated DACs and ADC for Control and Diagnostic Management
- Output Polarity Select
- Programmable Jitter Transfer Bandwidth to Adjust CDR Bandwidth
- CDR Bypass Mode for Low Data Rate Operation
- Automatic Power Control (APC) Loop with Selectable Monitor PD Range
- Programmable Transmit Input Equalizer
- Transmitter Cross-Point Adjust and De-Emphasis
- Includes Laser Safety Features
- Power Supply Monitor and Temperature Sensor
- Single 2.5 V Supply
- –40°C to 100°C Operation
- Surface Mount 4 mm x 4 mm 32-Pin QFN Package with 0.4 mm Pitch

2 Applications

- 10-Gbps Passive Optical Network (PON), Optical Line Terminal (OLT) Transceivers for FTTx deployment
- XFP and SFP+ 10-Gbps SONET OC-192 Optical Transceivers
- XFP and SFP+ 10GBASE-ER/ZR Optical Transceivers
- 8x and 10x Fibre Channel Optical Transmitters

3 Description

The ONET1131EC is a 2.5-V EML modulator driver with transmit clock and data recovery (CDR) designed to operate between 9.8 Gbps and 11.7 Gbps without the need for a reference clock. CDR bypass mode can be used for operation at lower data rates and a two-wire serial interface allows digital control of features like output polarity select and input equalization.

The transmit path consists of an adjustable input equalizer for equalization of up to 300 mm (12 inches) of microstrip or stripline transmission line of FR4 printed circuit boards, a multi-rate CDR and an output modulator driver. Output waveform control, in the form of cross-point adjustment and de-emphasis, is available to improve the optical eye mask margin. The device provides bias current for the laser and an integrated automatic power control (APC) loop to compensate for variations in average optical power over voltage, temperature and time.

The ONET1131EC contains internal analog to digital and digital to analog converters to support transceiver management and eliminate the need for special purpose microcontrollers.

Device Information⁽¹⁾

| PART NUMBER | PACKAGE | BODY SIZE (NOM) |
|-------------|-----------|-------------------|
| ONET1131EC | VQFN (32) | 4.00 mm x 4.00 mm |

(1) For all available packages, see the orderable addendum at the end of the data sheet.

Simplified Block Diagram

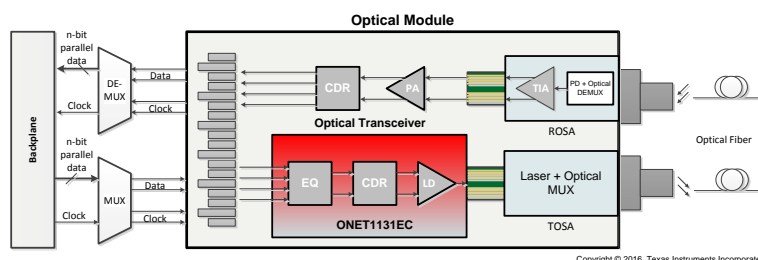


Table of Contents

| | | | |
|---|-----------|--|-----------|
| 1 Features | 1 | 7.3 Feature Description | 16 |
| 2 Applications | 1 | 7.4 Device Functional Modes | 21 |
| 3 Description | 1 | 7.5 Programming | 21 |
| 4 Revision History | 2 | 7.6 Register Mapping | 22 |
| 5 Pin Configuration and Function | 3 | 8 Application Information and Implementations .. | 35 |
| 6 Specifications | 5 | 8.1 Application Information | 35 |
| 6.1 Absolute Maximum Ratings | 5 | 8.2 Typical Application, Transmitter Differential Mode .. | 35 |
| 6.2 ESD Ratings | 5 | 9 Power Supply Recommendations | 39 |
| 6.3 Recommended Operating Conditions | 5 | 10 Layout | 40 |
| 6.4 Thermal Information | 6 | 10.1 Layout Guidelines | 40 |
| 6.5 DC Electrical Characteristics | 6 | 10.2 Layout Example | 40 |
| 6.6 AC Electrical Characteristics | 8 | 11 Device and Documentation Support | 41 |
| 6.7 Timing Requirements | 9 | 11.1 Receiving Notification of Documentation Updates .. | 41 |
| 6.8 Timing Diagram Definitions | 10 | 11.2 Community Resources | 41 |
| 6.9 Typical Characteristics | 11 | 11.3 Trademarks | 41 |
| 7 Detailed Description | 15 | 11.4 Electrostatic Discharge Caution | 41 |
| 7.1 Overview | 15 | 11.5 Glossary | 41 |
| 7.2 Functional Block Diagram | 15 | 12 Mechanical, Packaging, and Orderable Information | 41 |

4 Revision History

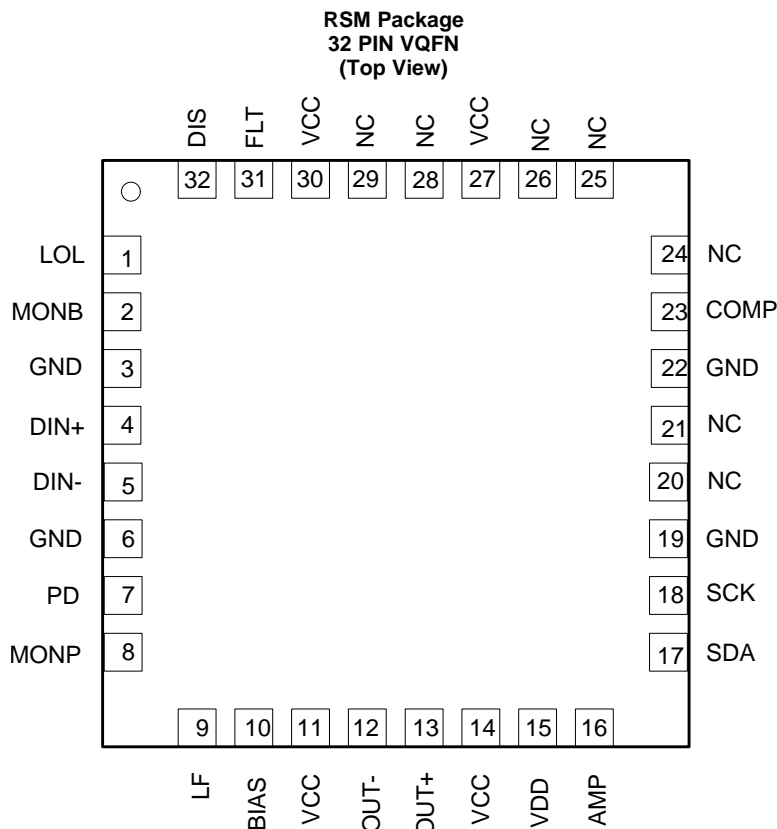
Changes from Original (September 2016) to Revision A

Page

| | |
|---|-----------|
| • Deleted sentence "however, this function..." from the second paragraph of the <i>CDR</i> section | 16 |
| • Deleted the <i>RX Registers</i> section from <i>Register Mapping</i> | 23 |
| • Deleted sentence "RX_CDRBP must be set to 1 for this function to operate." From Bit 3 of <i>Table 6</i> | 25 |
| • Deleted the <i>RX Registers 42 (offset = 0000 0000 [reset = 0h])</i> section from <i>Register Mapping</i> | 33 |

5 Pin Configuration and Function

The ONET1131EC is packaged in a small footprint 4 mm x 4 mm 32 pin RoHS compliant QFN package with a lead pitch of 0.4 mm.



Pin Functions

| NUMBER | NAME | Type | DESCRIPTION |
|--------|----------------|-------------|--|
| LOL | 1 | Digital-out | Loss of lock indicator. High level indicates the transmitter CDR is out of lock. Open drain output. Requires an external 4.7 k Ω to 10 k Ω pull-up resistor to VCC for proper operation. This pin is 3.3 V tolerant. |
| MONB | 2 | Analog-out | Bias current monitor. |
| GND | 3, 6, 19, 22 | Supply | Circuit ground. |
| DIN+ | 4 | Analog-in | Non-inverted transmitter data input. On-chip differentially 100 Ω terminated to TXIN-. Must be AC coupled. |
| DIN- | 5 | Analog-in | Inverted transmitter data input. On-chip differentially 100 Ω terminated to TXIN+. Must be AC coupled. |
| PD | 7 | Analog | Photodiode input. Pin can source or sink current dependent on register setting. |
| MONP | 8 | Analog-out | Photodiode current monitor. |
| LF | 9 | Analog-in | Transmitter loop filter capacitor. |
| BIAS | 10 | Analog | Sinks or sources the bias current for the laser in both APC and open loop modes. |
| VCC | 11, 14, 27, 30 | Supply | 2.5 V \pm 5% supply. |
| OUT- | 12 | CML-out | Inverted transmitter data output. Internally terminated in single-ended operation mode. |
| OUT+ | 13 | CML-out | Non-Inverted transmitter data output. |
| VDD | 15 | Supply | 2.5 V \pm 5% supply for the digital circuitry. |
| AMP | 16 | Analog-in | Output amplitude control. Output amplitude can be adjusted by applying a voltage of 0 to 2 V to this pin. Leave open when not used. |

Pin Functions (continued)

| NUMBER | NAME | Type | DESCRIPTION |
|--------|-------------------------------|----------------|--|
| SDA | 17 | Digital-in/out | 2-wire interface serial data input. Requires an external 4.7-k Ω to 10-k Ω pull-up resistor to VCC. This pin is 3.3-V tolerant. |
| SCK | 18 | Digital-in | 2-wire interface serial clock input. Requires an external 4.7-k Ω to 10-k Ω pull-up resistor to VCC. This pin is 3.3-V tolerant. |
| NC | 20, 21, 24, 25, 26, 28, 29 | | Do not connect |
| COMP | 23 | Analog | Compensation pin used to control the bandwidth of the APC loop. Connect a 0.01- μ F capacitor to ground. |
| FLT | 31 | Digital-out | Transmitter fault detection flag. High level indicates that a fault has occurred. Open drain output. Requires an external 4.7 k Ω to 10 k Ω pull-up resistor to VCC for proper operation. This pin is 3.3-V tolerant. |
| DIS | 32 | Digital-in | Disables the bias current when set to high state. Includes a 250-k Ω pull-up resistor to VCC. Requires an external 4.7 k Ω to 10 k Ω pull-up resistor to VCC for proper operation Toggle to reset a fault condition. This is an ORed function with the TXBIASEN bit (bit 2 in register 1). This pin is 3.3-V tolerant. |

6 Specifications

6.1 Absolute Maximum Ratings ⁽¹⁾⁽²⁾

over operating free-air temperature range (unless otherwise noted)

| | | MIN | MAX | UNIT |
|--|---|------|-----|------|
| Supply voltage | at VCC, VDD | -0.5 | 3 | V |
| Voltage | at 3.3-V tolerant pins LOL, SDA, SCK, FLT, DIS | -0.5 | 3.6 | V |
| | at all other pins MONB, DIN+, DIN-, PD, MONP, LF, BIAS, OUT-, OUT+, AMP, COMP | -0.5 | 3 | V |
| Maximum current at transmitter input pins | DIN+, DIN- | | 10 | mA |
| Maximum current at transmitter output pins | OUT+, OUT- | | 125 | mA |
| Maximum junction temperature, T _J | | | 125 | °C |
| Storage temperature, T _{stg} | | -65 | 150 | °C |

- (1) Stresses beyond those listed under “absolute maximum ratings” may cause permanent damage to the device. These are stress ratings only and functional operation of the device at these or any other conditions beyond those indicated under “recommended operating conditions” is not implied. Exposure to absolute–maximum–rated conditions for extended periods may affect device reliability.
- (2) All voltage values are with respect to network ground terminal.

6.2 ESD Ratings

| | | VALUE | UNIT |
|--------------------|--|-------|------|
| V _(ESD) | Electrostatic discharge Human-body model (HBM), per ANSI/ESDA/JEDEC JS-001 ⁽¹⁾ | ±2000 | V |

- (1) JEDEC document JEP155 states that 500-V HBM allows safe manufacturing with a standard ESD control process.

6.3 Recommended Operating Conditions

over operating free-air temperature range (unless otherwise noted)

| | | MIN | TYP | MAX | UNIT |
|--------------------|---------------------------------------|---|------|------|------|
| V _{CC} | Supply Voltage | 2.37 | 2.5 | 2.63 | V |
| V _{IH} | Digital input high voltage | 2 | | | V |
| V _{IL} | Digital input low voltage | | | | V |
| | Photodiode current range | Control bit TXPDRNG = 1x, step size = 3 μA | 3080 | | μA |
| | | Control bit TXPDRNG = 01, step size = 1.5 μA | 1540 | | |
| | | Control bit TXPDRNG = 00, step size = 0.75 μA | 770 | | |
| | Serial Data rate | TXCDDR_DIS = 0 | 9.8 | 11.7 | Gbps |
| | | TXCDDR_DIS = 1 | 1 | 11.7 | |
| V _{AMP} | Amplitude control input voltage range | 0 | | 2 | V |
| t _{R(IN)} | Input rise time | 20%–80% | 30 | 45 | ps |
| t _{F(IN)} | Input fall time | 20%–80% | 30 | 45 | ps |
| T _C | Temperature at thermal pad | -40 | | 100 | °C |

6.4 Thermal Information

| THERMAL METRIC ⁽¹⁾ | | RSM (VQFN) | UNIT |
|-------------------------------|--|------------|------|
| | | 32 PINS | |
| R _{θJA} | Junction-to-ambient thermal resistance | 37.2 | °C/W |
| R _{θJctop} | Junction-to-case (top) thermal resistance | 30.1 | °C/W |
| R _{θJB} | Junction-to-board thermal resistance | 7.8 | °C/W |
| ψ _{JT} | Junction-to-top characterization parameter | 0.4 | °C/W |
| ψ _{JB} | Junction-to-board characterization parameter | 7.6 | °C/W |
| R _{θJcbot} | Junction-to-case (bottom) thermal resistance | 2.4 | °C/W |

(1) For more information about traditional and new thermal metrics, see the [Semiconductor and IC Package Thermal Metrics](#) application report.

6.5 DC Electrical Characteristics

Over recommended operating conditions, open loop operation, V_{OUT} = 2 V_{PP} single-ended, I_(BIAS) = 80 mA, unless otherwise noted. Typical operating condition is at V_{CC} = 2.5 V and T_A = 25°C

| PARAMETER | | TEST CONDITIONS | MIN | TYP | MAX | UNIT |
|-------------------------|--|--|------|------|------------------------|------|
| V _{CC} | Supply voltage | | 2.37 | 2.5 | 2.63 | V |
| I _{VCC} | Supply current in single-ended TX mode with CDRs enabled | TXMODE = 1, TXCDR_DIS = 0, TX V _{OUT} = 2 V _{PP} single-ended, I _(BIAS) = 0 mA | | 158 | 193 | mA |
| | Power dissipation in single-ended TX mode with CDRs enabled | | | 380 | 508 | mW |
| | Supply current in differential TX mode with CDRs enabled | TXMODE = 0, TXCDR_DIS = 0, TX V _{OUT} = 2 V _{PP} single-ended, I _(BIAS) = 0 mA | | 197 | 237 | mA |
| | Power dissipation in differential TX mode with CDRs enabled | | | 493 | 623 | mW |
| | Supply current in single-ended TX mode with CDRs disabled | TXMODE = 1, TXCDR_DIS = 1, TX V _{OUT} = 2 V _{PP} single-ended, I _(BIAS) = 0 mA | | 119 | 193 | mA |
| | Power dissipation in single-ended TX mode with CDRs disabled | | | 298 | 376 | mW |
| | Supply current in differential TX mode with CDRs disabled | TXMODE = 0, TXCDR_DIS = 1, TX V _{OUT} = 2 V _{PP} single-ended, I _(BIAS) = 0 mA; | | 164 | 200 | mA |
| | Power dissipation in differential TX mode with CDRs disabled | | | 410 | 526 | mW |
| R _(IN) | Data input resistance | Differential between DIN+ / DIN– | | 100 | | Ω |
| | Data input termination mismatch | | | | 5% | |
| R _(OUT) | Output resistance | Single-ended at OUT+ or OUT– | | 60 | | Ω |
| | Digital input current | DIS pull up to V _{CC} | –20 | | 20 | μA |
| V _{OH} | Digital output high voltage | LOL, FLT pull-up to V _{CC} , I _{SOURCE} = 37.5 μA | 2.1 | | | V |
| V _{OL} | Digital output low voltage | LOL, FLT pull-up to V _{CC} , I _{SINK} = 350 μA | | | 0.4 | V |
| I _(BIAS-MIN) | Minimum bias current | See ⁽¹⁾ | | | 5 | mA |
| I _(BIAS-MAX) | Maximum bias current | Source. BIASPOL = 0, DAC set to maximum, open and closed loop | 145 | 150 | | mA |
| | | Sink. BIASPOL = 1, DAC set to maximum, open and closed loop | 95 | 100 | | mA |
| I _(BIAS-DIS) | Bias current during disable | | | | 100 | μA |
| | Average power stability | APC loop enabled | | ±0.5 | | dB |
| | Bias pin compliance voltage | Source. TXBIASPOL = 0 | | | V _{CC} - 0.45 | V |
| | | Sink. TXBIASPOL = 1 | 0.45 | | | V |
| | Temperature sensor accuracy | With 1-point external mid-scale calibration | | ±3 | | °C |

(1) The bias current can be set below the specified minimum according to the corresponding register setting; however, in closed loop operation settings below the specified value may trigger a fault.

DC Electrical Characteristics (continued)

Over recommended operating conditions, open loop operation, $V_{OUT} = 2 V_{PP}$ single-ended, $I_{(BIAS)} = 80 \text{ mA}$, unless otherwise noted. Typical operating condition is at $V_{CC} = 2.5 \text{ V}$ and $T_A = 25^\circ\text{C}$

| PARAMETER | | TEST CONDITIONS | MIN | TYP | MAX | UNIT |
|---|---|---|------|-------|------|------|
| $V_{(PD)}$ | Photodiode reverse bias voltage | APC active, $I_{(PD)} = 1500 \mu\text{A}$ | 1.3 | 2.3 | | V |
| | Photodiode fault current level | Percent of target $I_{(PD)}$ ⁽²⁾ | | 150% | | |
| | Photodiode current monitor ratio | $I_{(MONP)} / I_{(PD)}$ with control bit PDRNG = 1X | 10% | 12.5% | 15% | |
| | | $I_{(MONP)} / I_{(PD)}$ with control bit PDRNG = 01 | 20% | 25% | 30% | |
| $I_{(MONP)} / I_{(PD)}$ with control bit TXPDRNG = 00 | | 40% | 50% | 60% | | |
| Monitor diode DMI accuracy | | With external mid-scale calibration | -15% | | 15% | |
| Bias current monitor ratio | | $I_{(MONB)} / I_{(BIAS)}$ (nominal 1/100 = 1%), $V_{(MONB)} < 1.5\text{V}$ | 0.9% | 1% | 1.1% | |
| Bias current DMI accuracy | | $I_{(BIAS)} \geq 20 \text{ mA}$ | -15% | | 15% | |
| Power supply monitor accuracy | | With external mid-scale calibration | -2% | | 2% | |
| $V_{CC(RST)}$ | V_{CC} reset threshold voltage | V_{CC} voltage level which triggers power-on reset | | 1.8 | 2.1 | V |
| $V_{CC(RSTHYS)}$ | V_{CC} reset threshold voltage hysteresis | | | 100 | | mV |
| $V_{(MONB-FLT)}$ | Fault voltage at MONB | TXFLTEN = 1, TXDMONB = 0, Fault occurs if voltage at MONB exceeds this value | 1.15 | 1.2 | 1.25 | V |
| $V_{(MONP-FLT)}$ | Fault voltage at MONP | TXFLTEN = 1, TXMONPFLT = 1, TXDMONP = 0, Fault occurs if voltage at MONP exceeds this value | 1.15 | 1.2 | 1.25 | V |

(2) Specified by design over process, supply and temperature variation

6.6 AC Electrical Characteristics

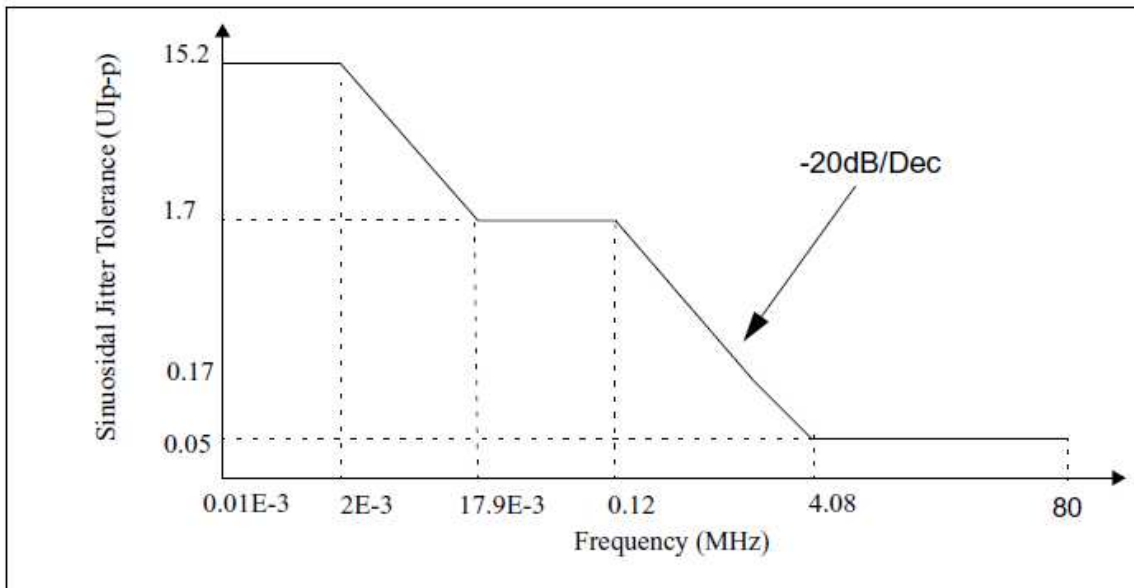
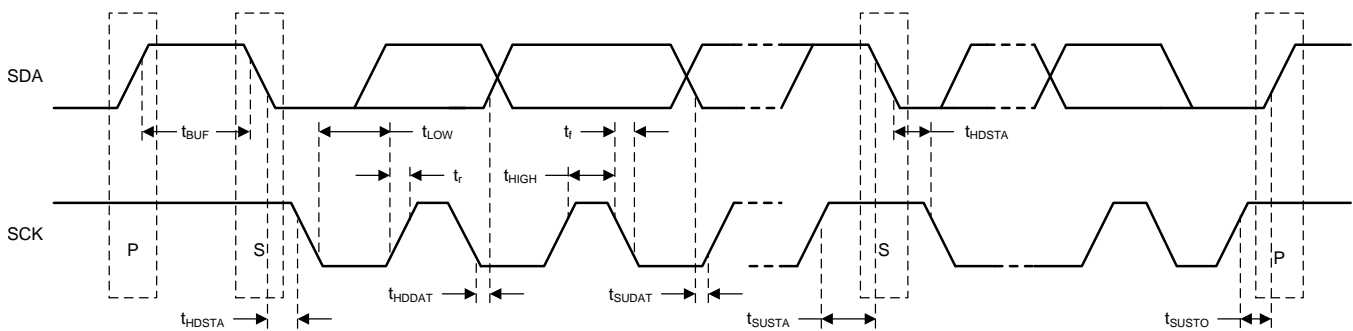
Over recommended operating conditions, open loop operation, $V_{OUT} = 2 V_{PP}$ single-ended, $I_{(BIAS)} = 80$ mA unless otherwise noted. Typical operating condition is at $V_{CC} = 2.5$ V and $T_A = 25^\circ\text{C}$

| PARAMETER | | TEST CONDITIONS | MIN | TYP | MAX | UNIT |
|--|--|---|------|-----|------|--------------------|
| TX INPUT SPECIFICATIONS | | | | | | |
| | CDR lock range | CPRI, Ethernet, SONET, Fibre Channel | 9.80 | | 11.7 | Gbps |
| SDD11 | Differential input return loss | 0.05 GHz < f ≤ 0.1 GHz | 20 | | | dB |
| | | 0.1 GHz < f ≤ 5.5 GHz | 12 | 15 | | |
| | | 5.5 GHz < f < 12 GHz | 8 | | | |
| SDD11 | Differential to common mode conversion | 0.1 GHz < f < 12 GHz | 10 | 15 | | dB |
| SDD11 | Common mode input return loss | 0.1 GHz < f < 12 GHz | 3 | | | dB |
| | Input AC common mode voltage tolerance | | 15 | | | mV |
| | Total Non-DDJ | Total jitter less ISI | | | 0.45 | UI _{PP} |
| T _(JTX) | Total Jitter | | | | 0.65 | UI _{PP} |
| S _(JTX) | Sinusoidal Jitter Tolerance | With addition of input jitter, See Figure 1 | | | | UI _{PP} |
| V _{IN} | Differential input voltage swing | | 100 | | 1000 | mV _{PP} |
| EQ _(boost) | EQ high freq boost | Maximum setting; 7 GHz | 6 | 9 | | dB |
| TX OUTPUT SPECIFICATIONS | | | | | | |
| | Differential output return loss | 0.01 GHz < f < 12 GHz | | 12 | | dB |
| V _{O(MIN)} | Minimum output amplitude | AC Coupled Outputs, 50-Ω single-ended load | | | 0.5 | V _{PP} |
| TX OUTPUT SPECIFICATIONS in SINGLE-ENDED MODE of OPERATION (TXMODE = 1) | | | | | | |
| V _{O(MAX)} | Maximum output amplitude | AC Coupled Outputs, 50-Ω load, single-ended | 2 | | | V _{PP} |
| | Output amplitude stability | AC Coupled Outputs, 50-Ω load, single-ended | | 230 | | mV _{PP} |
| | High Cross Point Control Range | 50-Ω load, single-ended | 70% | 75% | | |
| | Low Cross Point Control Range | 50-Ω load, single-ended | | 35% | 40% | |
| | Cross Point Stability | 50-Ω load, single-ended | -5 | | 5 | pp |
| | Output de-emphasis | TXDEADJ[0..3] = 1111, TXPKSEL = 0 | | 5 | | dB |
| | | TXDEADJ[0..3] = 1111, TXPKSEL = 1 | | 6 | | |
| TX OUTPUT SPECIFICATIONS in DIFFERENTIAL MODE of OPERATION (TXMODE = 0) | | | | | | |
| V _{O(MAX)} | Maximum output amplitude | AC Coupled Outputs, 100-Ω differential load | 3.6 | | | V _{PP} |
| | Output amplitude stability | AC Coupled Outputs, 100-Ω differential load | | 230 | | mV _{PP} |
| | High Cross Point Control Range | 100-Ω differential load | 65% | 75% | | |
| | Low Cross Point Control Range | 100-Ω differential load | | 35% | 40% | |
| | Cross Point Stability | 100-Ω differential load | -5 | | 5 | pp |
| | Output de-emphasis | TXDEADJ[0..3] = 1111, TXPKSEL = 0 | | 5 | | dB |
| | | TXDEADJ[0..3] = 1111, TXPKSEL = 1 | | 6 | | |
| CDR SPECIFICATIONS | | | | | | |
| BW _(TX) | Jitter Transfer Bandwidth | 9.95 Gbps, PRBS31 | | | 8 | MHz |
| J _(PTX) | Jitter Peaking | > 120 kHz | | | 1 | dB |
| J _{GEN(rms)} | Random RMS jitter generation | Clock pattern, 50 kHz to 80 MHz | | | 6 | mUI _{rms} |
| J _{GEN(PP)} | Total jitter generation | Clock pattern, 50 kHz to 80 MHz, BER = 10 ⁻¹² | | | 60 | mUI _{PP} |

6.7 Timing Requirements

Over recommended operating conditions, typical operating condition is at $V_{CC} = 2.5\text{ V}$ and $T_A = 25^\circ\text{C}$

| | | | MIN | TYP | MAX | UNIT |
|---|----------------------------------|---|-----|-----|------|-------------------|
| $t_{(APC)}$ | APC time constant | $C_{APC} = 0.01\ \mu\text{F}$, $I_{PD} = 500\ \mu\text{A}$, PD coupling ratio CR = 150, PDRNG = 01 | | 50 | | μs |
| $t_{(INIT1)}$ | Power-on to initialize | Power-on to registers ready to be loaded | | 0.2 | 1 | ms |
| $t_{(INIT2)}$ | Initialize to transmit | Register load STOP command to part ready to transmit valid data | | | 2 | ms |
| $t_{(OFF)}$ | Transmitter disable time | Rising edge of DIS to $I_{(BIAS)} \leq 0.1 \times I_{(BIAS-NOMINAL)}$ | | 1 | 5 | μs |
| $t_{(ON)}$ | Disable negate time | Falling edge of DIS to $I_{(BIAS)} \geq 0.9 \times I_{(BIAS-NOMINAL)}$ | | | 1 | ms |
| $t_{(RESET)}$ | DIS pulse width | Time DIS must held high to reset part | 100 | | | ns |
| $t_{(FAULT)}$ | Fault assert time | Time from fault condition to FLT high | | | 50 | μs |
| OUTPUT SPECIFICATIONS in SINGLE-ENDED MODE of OPERATION (TXMODE = 1) | | | | | | |
| $t_{R(OUTTX)}$ | Output rise time | 20% - 80%, AC Coupled Outputs, 50- Ω load, single-ended | | 30 | 42 | ps |
| $t_{F(OUTTX)}$ | Output fall time | 20% - 80%, AC Coupled Outputs, 50- Ω load, single-ended | | 30 | 42 | ps |
| $ISI_{(TX)}$ | Intersymbol interference | TXEQ_DIS = 1, 11.3 Gbps, PRBS9 pattern, 150-mVpp, 600-mVpp, 1200-mVpp differential input voltage | | 4 | 12 | ps |
| | | TXEQ_DIS = 0, 11.3 Gbps, PRBS9 pattern, 150-mVpp, 600-mVpp, 1200-mVpp differential input voltage, maximum equalization with 18-inch transmission line at the input. | | 7 | | |
| $R_{(JTX)}$ | Serial data output random jitter | | | 0.4 | 0.75 | ps _{RMS} |
| | Output de-emphasis width | TXPKSEL = 0 | | 28 | | ps |
| | | TXPKSEL = 1 | | 35 | | |
| OUTPUT SPECIFICATIONS in DIFFERENTIAL MODE of OPERATION (TXMODE = 0) | | | | | | |
| $t_{R(OUTTX)}$ | Output rise time | 20%–80%, AC Coupled Outputs, 100- Ω differential load | | 30 | 42 | ps |
| $t_{F(OUTTX)}$ | Output fall time | 20%–80%, AC Coupled Outputs, 100- Ω differential load | | 30 | 42 | ps |
| $ISI_{(TX)}$ | Intersymbol interference | TXEQ_DIS = 1, 11.3 Gbps, PRBS9 pattern, 150-mVpp, 600-mVpp, 1200-mVpp differential input voltage | | 4 | 10 | ps |
| | | TXEQ_DIS = 0, 11.3 Gbps, PRBS9 pattern, 150-mVpp, 600-mVpp, 1200-mVpp differential input voltage, maximum equalization with 18-inch transmission line at the input. | | 7 | | |
| $R_{(JTX)}$ | Serial data output random jitter | | | 0.4 | 0.75 | ps _{RMS} |
| | Output Peaking Width | TXPKSEL = 0 | | 28 | | ps |
| | | TXPKSEL = 1 | | 35 | | |
| CDR SPECIFICATIONS | | | | | | |
| $t_{(Lock,TX)}$ | CDR Acquisition time | | | | 2 | ms |
| | LOL assert time | | | | 500 | μs |


Figure 1. Input Sinusoidal Jitter Tolerance (INF-8077i Rev. 4.5 XFP MSA)

Figure 2. 2-Wire Interface Diagram

6.8 Timing Diagram Definitions

| | | MIN | TYP | MAX | UNIT |
|-------------|---|-----|-----|-----|---------|
| f_{SCK} | SCK clock frequency | | | 400 | kHz |
| t_{BUF} | Bus free time between START and STOP conditions | 1.3 | | | μ s |
| t_{HDSTA} | Hold time after repeated START condition. After this period, the first clock pulse is generated | 0.6 | | | μ s |
| t_{LOW} | Low period of the SCK clock | 1.3 | | | μ s |
| t_{HIGH} | High period of the SCK clock | 0.6 | | | μ s |
| t_{SUSTA} | Setup time for a repeated START condition | 0.6 | | | μ s |
| t_{HDDAT} | Data HOLD time | 0 | | | μ s |
| t_{SUDAT} | Data setup time | 100 | | | ns |
| t_R | Rise time of both SDA and SCK signals | | | 300 | ns |
| t_F | Fall time of both SDA and SCK signals | | | 300 | ns |
| t_{SUSTO} | Setup time for STOP condition | 0.6 | | | μ s |

6.9 Typical Characteristics

Typical operating condition is at $V_{CC} = 2.5\text{ V}$, $T_A = 25^\circ\text{C}$, $V_{OUT} = 2\text{ V}_{PP}$ Single-ended, $DIN = 600\text{ mV}_{PP}$ differential, CDR enabled (unless otherwise noted).

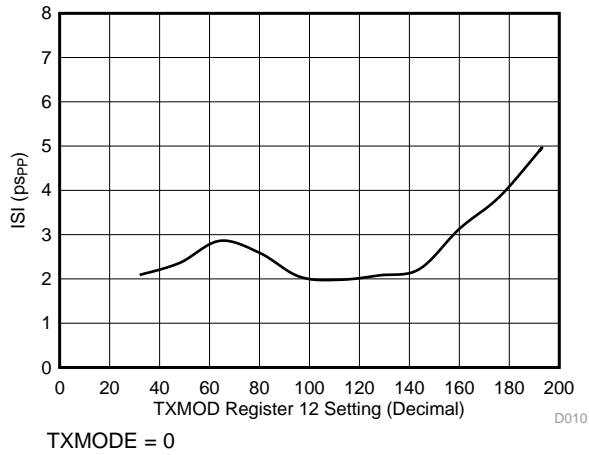


Figure 3. Deterministic Jitter vs Modulation Current

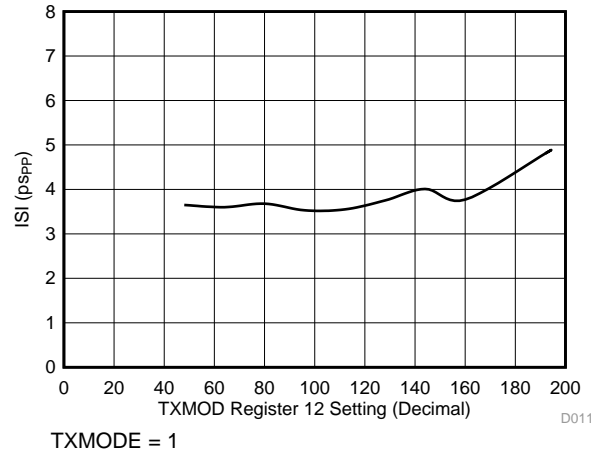


Figure 4. Deterministic Jitter vs Modulation Current

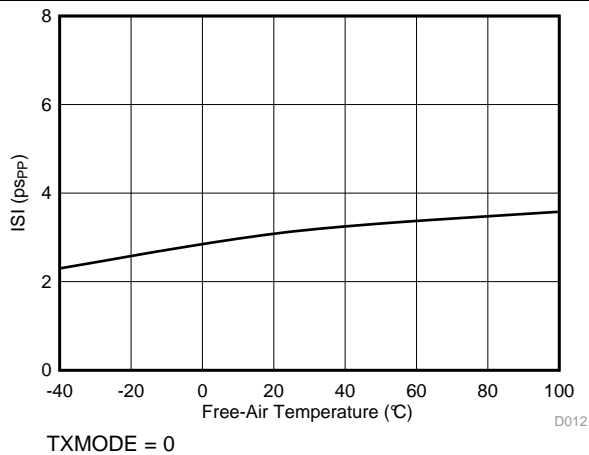


Figure 5. Deterministic Jitter vs Temperature

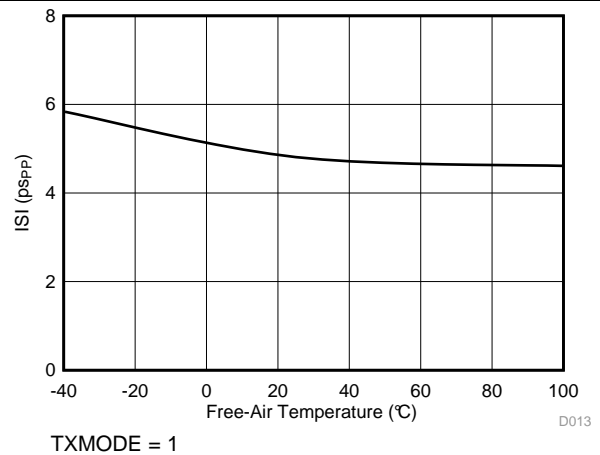


Figure 6. Deterministic Jitter vs Temperature

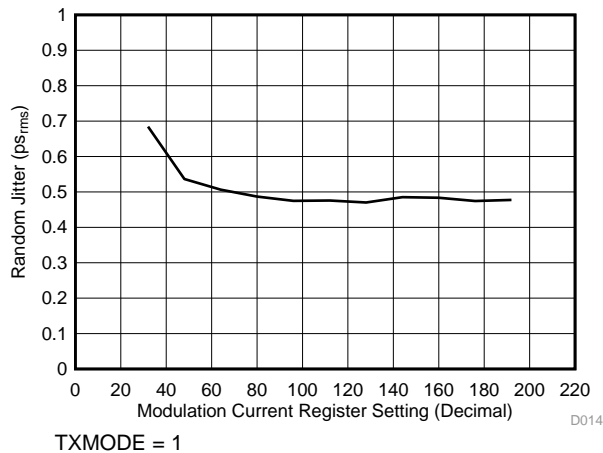


Figure 7. Random Jitter vs Modulation Current

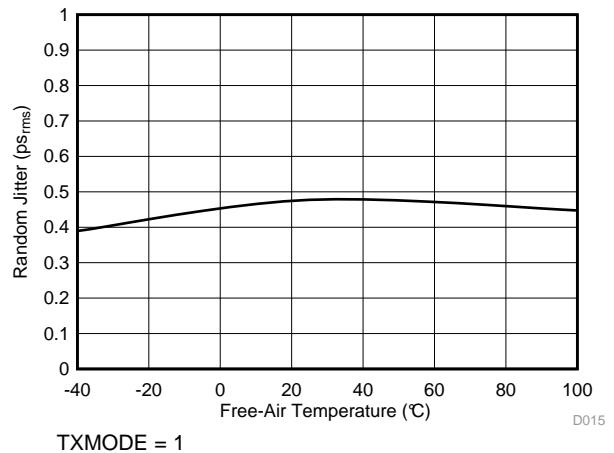


Figure 8. Random Jitter vs Temperature

Typical Characteristics (continued)

Typical operating condition is at $V_{CC} = 2.5\text{ V}$, $T_A = 25^\circ\text{C}$, $V_{OUT} = 2\text{ V}_{PP}$ Single-ended, $DIN = 600\text{ mV}_{PP}$ differential, CDR enabled (unless otherwise noted).

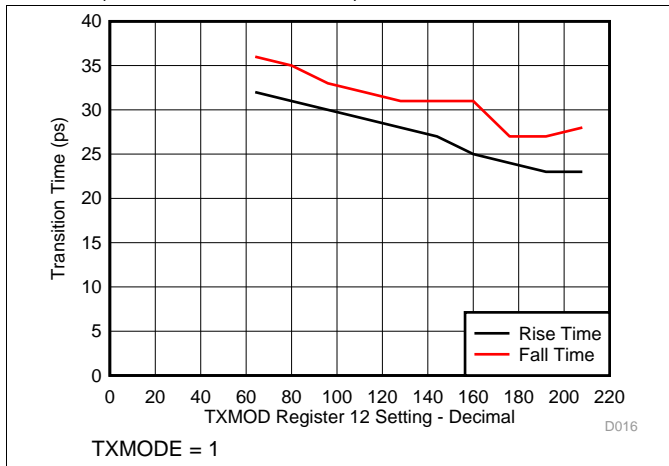


Figure 9. Rise-Time and Fall-Time vs Modulation Current

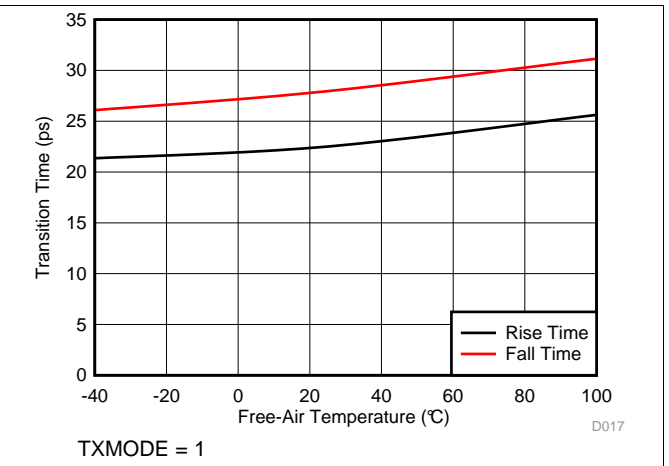


Figure 10. Rise-Time and Fall-Time vs Temperature

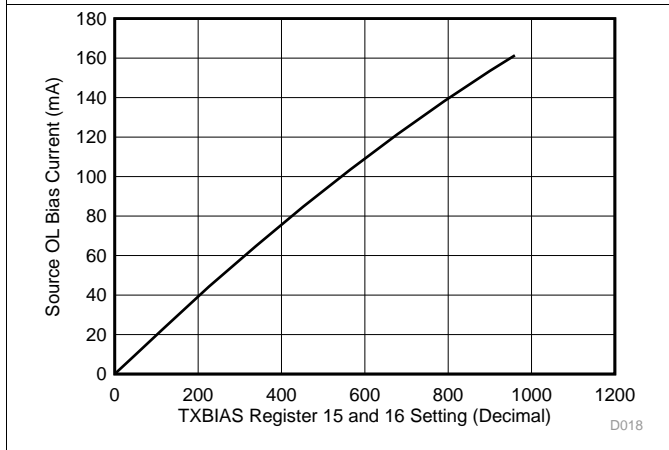


Figure 11. Source Bias Current in Open Loop Mode vs Bias Register Setting

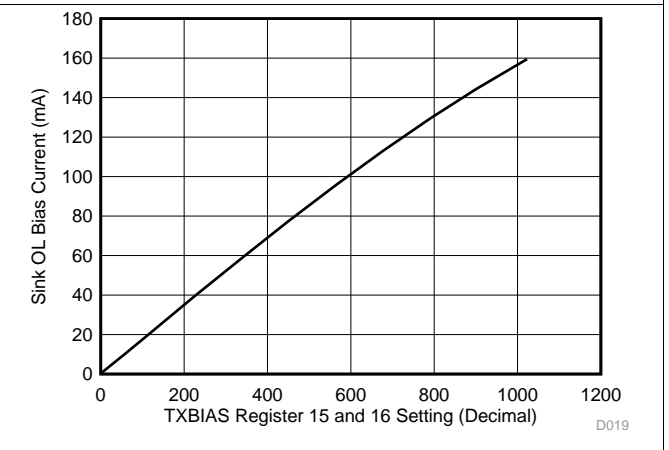


Figure 12. Sink Bias Current in Open Loop Mode vs Bias Register Setting

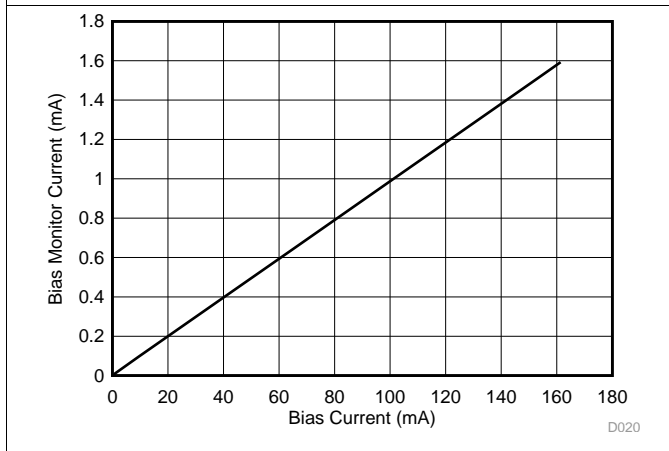


Figure 13. Bias-Monitor Current $I_{(MONB)}$ vs Bias Current

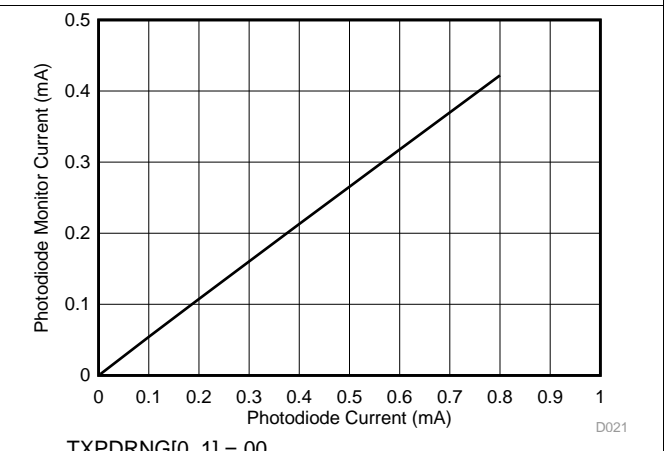


Figure 14. Photodiode-Monitor Current $I_{(MONP)}$ vs PD Current

Typical Characteristics (continued)

Typical operating condition is at $V_{CC} = 2.5\text{ V}$, $T_A = 25^\circ\text{C}$, $V_{OUT} = 2 V_{PP}$ Single-ended, $DIN = 600\text{ mV}_{PP}$ differential, CDR enabled (unless otherwise noted).

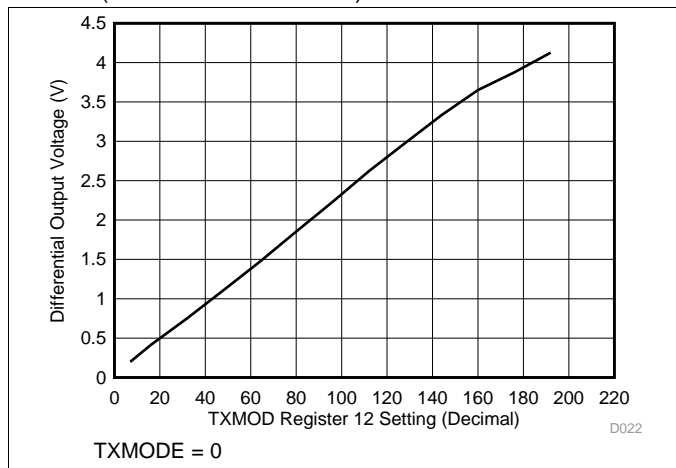


Figure 15. Output Voltage vs Modulation Current

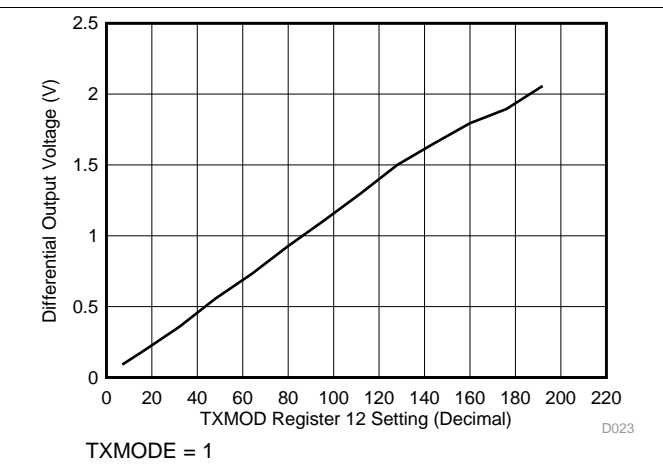


Figure 16. Output Voltage vs Modulation Current

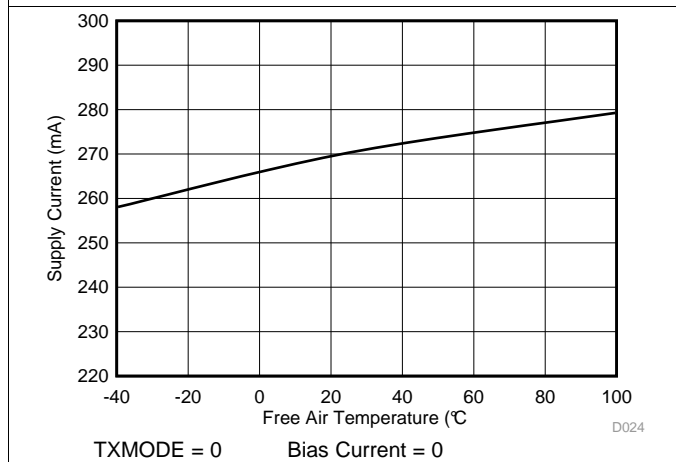


Figure 17. Supply Current vs Temperature

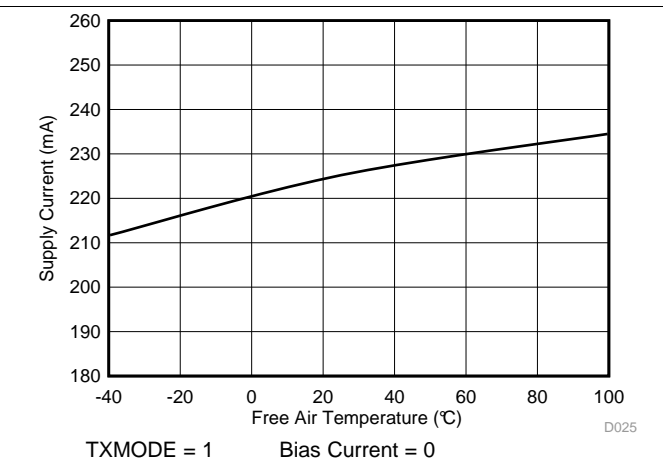


Figure 18. Supply Current vs Temperature

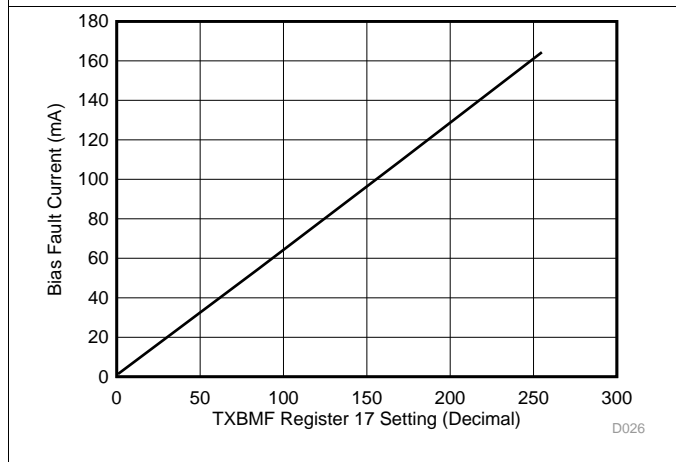


Figure 19. Bias Current Monitor Fault vs TXBMF Register Setting

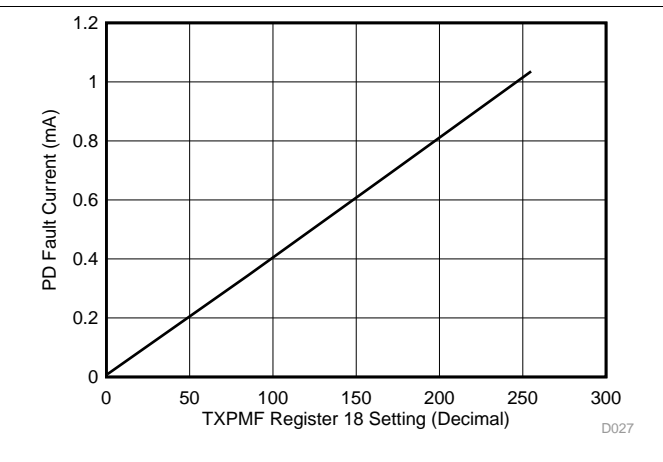


Figure 20. Photodiode Current Monitor Fault vs TXPMF Register Setting

Typical Characteristics (continued)

Typical operating condition is at $V_{CC} = 2.5\text{ V}$, $T_A = 25^\circ\text{C}$, $V_{OUT} = 2\text{ V}_{PP}$ Single-ended, $DIN = 600\text{ mV}_{PP}$ differential, CDR enabled (unless otherwise noted).

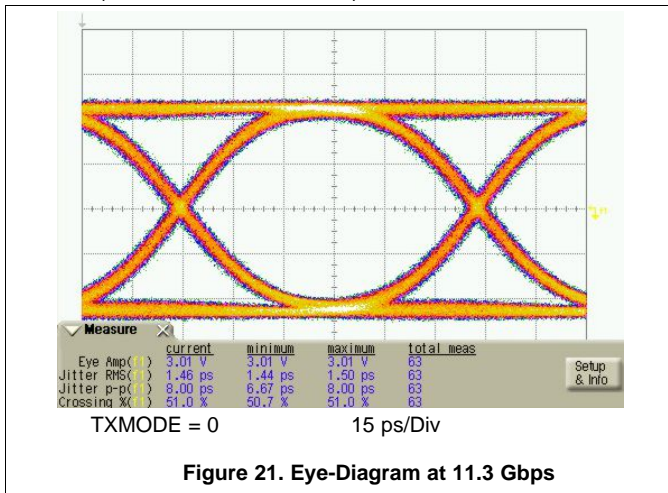


Figure 21. Eye-Diagram at 11.3 Gbps

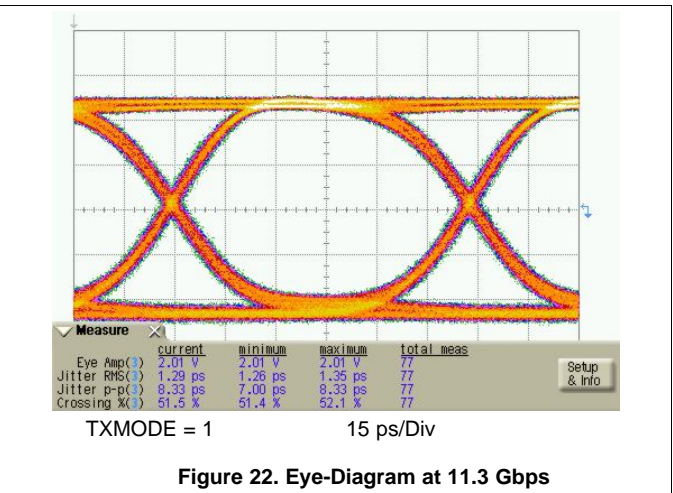


Figure 22. Eye-Diagram at 11.3 Gbps

7 Detailed Description

7.1 Overview

A simplified block diagram of the ONET1131EC is shown in [Functional Block Diagram](#).

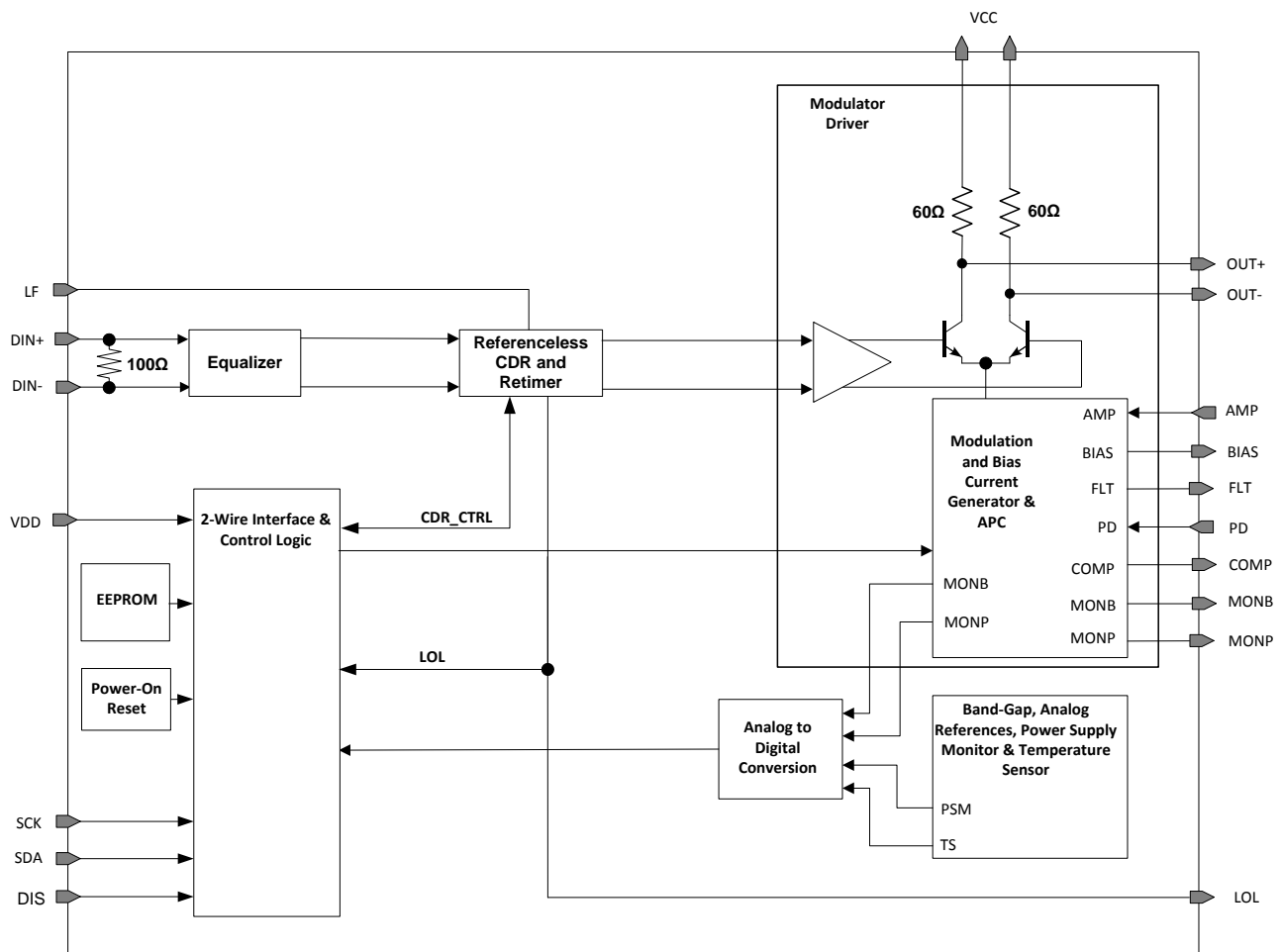
The ONET1131EC consists of a transmitter path, an analog reference block, an analog to digital converter, and a 2-wire serial interface and control logic block with power-on reset.

The transmit path consists of an adjustable input equalizer, a multi-rate CDR and an output modulator driver. The output driver provides a differential output voltage but can be operated in a single-ended mode to reduce the power consumption. Output waveform control, in the form of cross-point adjustment and de-emphasis are available to improve the optical eye mask margin. Bias current for the laser is provided and an integrated automatic power control (APC) loop to compensate for variations in average optical power over voltage, temperature and time is included.

The ONET1131EC contains an analog to digital converter to support transceiver digital diagnostics and can report the supply voltage, laser bias current, laser photodiode current and internal temperature.

The 2-wire serial interface is used to control the operation of the device and read the status of the control registers.

7.2 Functional Block Diagram



Copyright © 2016, Texas Instruments Incorporated

7.3 Feature Description

7.3.1 Equalizer

The data signal is applied to an input equalizer by means of the input signal pins DIN+ / DIN–, which provide on-chip differential 100-Ω line termination. The equalizer is enabled by default and can be disabled by setting the transmitter equalizer disable bit TXEQ_DIS = 1 (bit 1 of [register 10](#)). Equalization of up to 300 mm (12 inches) of microstrip or stripline transmission line on FR4 printed circuit boards can be achieved. The amount of equalization is set through register settings TXCTLE [0..3] ([register 11](#)). The device can accept input amplitude levels from 100 mVpp up to 1000 mVpp.

7.3.2 CDR

The clock and data recovery function consists of a Phase-Locked Loop (PLL) and retimer. The CDR can be operated without a reference clock and the Voltage Controlled Oscillator (VCO) can cover 9.8 Gbps to 11.7 Gbps data rates. The PLL is phase locked to the incoming data stream and attenuates the high frequency jitter on the data, producing a recovered clean clock with substantially reduced jitter. An external capacitor for the PLL loop filter is connected to the LF pin. A value of 2.2 nF is recommended. The clean clock is used to retimer the incoming data, producing an output signal with reduced jitter, and in effect, resetting the jitter budget for the transmitter.

The CDR is enabled by default. The CDR can be disabled and bypassed by setting the transmitter CDR disable bit TXCDR_DIS = 1 (bit 4 of [register 10](#)). Alternatively, the CDR can be left powered on but bypassed by setting the transmitter CDR bypass bit TX_CDRBP = 1 (bit 3 of [register 10](#)).

The CDR is designed to meet the XFP Datacom requirements and Telecom requirements for a maximum of 1-dB jitter peaking at a frequency greater than 120 kHz. The CDR is not designed to meet the Telecom regenerator requirements of jitter peaking less than 0.03 dB at a frequency less than 120 kHz. The default CDR bandwidth is typically 4.5 MHz and can be adjusted using the SEL_RES[0..2] bits (bits 5 to 7 of [register 51](#)). Adjusting these bits changes the bandwidth of both the transmitter and receiver CDRs.

For the majority of applications, the default settings in [register 19](#) for the transmitter CDR can be used. However, for some applications or for test purposes, some modes of operation may be useful. The frequency detector for the PLL is set to an automatic mode of operation by default. When a signal is applied to the transmitter input the frequency detector search algorithm will be initiated to determine the frequency of the data. The default algorithm ensures a fast CDR lock time of less than 2 ms. The fast lock can be disabled by setting the transmitter CDR fast lock disable bit TXFL_DIS = 1 (bit 3 of [register 19](#)). Once the frequency has been detected then the frequency detector will be disabled and the supply current will decrease by approximately 10mA. In some applications, such as when there are long periods of idle data, it may be advantageous to keep the frequency detector permanently enabled by setting the transmitter frequency detector enable bit TXFD_EN = 1 (bit 5 of [register 19](#)). For test purposes, the frequency detector can be permanently disabled by setting the transmitter frequency detector disable bit TXFD_DIS = 1 (bit 4 of [register 19](#)). For fast lock times the frequency detector can be set to one of two preselected data rates using the transmitter frequency detection mode selection bits TXFD_MOD[0..1] (bits 6 and 7 of [register 19](#)). If it is desired to use the retimer at lower data rates than the standard 9.8 to 11.7Gbps then the transmitter divider ratio should be adjusted accordingly through TXDIV[0..2] (bits 0 to 2 of [register 19](#)). For example, for re-timed operation at 2.5 Gbps the divider should be set to divide by 4.

7.3.3 Modulator Driver

The modulation current is sunk from the common emitter node of the limiting output driver differential pair by means of a modulation current generator, which is digitally controlled by the 2-wire serial interface.

The collector nodes of the output stages are connected to the transmitter output pins TXOUT+ and TXOUT–. The collectors have internal 50Ω back termination resistors to VCC_TX. The outputs are optimized to drive a 50 Ω single-ended load and to obtain the maximum single-ended output voltage of 2.0Vpp, AC coupling and inductive pull-ups to VCC are required. For reduced power consumption the DC resistance of the inductive pull-ups should be minimized to provide sufficient headroom on the TXOUT+ and TXOUT– pins.

The polarity of the output pins can be inverted by setting the transmitter output polarity switch bit, TXOUTPOL (bit 5 of [register 10](#)) to 1. In addition, the output driver can be disabled by setting the transmitter output driver disable bit TXOUT_DIS = 1 (bit 6 of [register 10](#)).

Feature Description (continued)

The output driver is set to differential output by default. In order to reduce the power consumption for single-ended applications driving an electroabsorptive modulated laser (EML) the output drive [register 13](#) should be set to single-ended mode. The single-ended output signal is enabled by setting the transmitter mode select bit TXMODE = 1 (bit 6 of [register 13](#)). The positive output is active by default. To enable the negative output and disable the positive output set TXOUTSEL = 1 (bit 7 of [register 13](#)).

Output de-emphasis can be applied to the signal by adjusting the transmitter de-emphasis bits TXDEADJ[0..3] (bits 0 to 3 of [register 13](#)). In addition, the width of the applied de-emphasis can be increased by setting the transmitter output peaking width TXPKSEL = 1 (bit 6 of [register 11](#)). The wide peaking width would typically be useful for a more capacitive transmitter load. How de-emphasis is applied is controlled through the TXSTEP bit (bit 5 of [register 13](#)). Setting TXSTEP = 1 delays the time of the applied de-emphasis and has more of an impact on the falling edge. A graphical representation of the two de-emphasis modes is shown in [Figure 23](#). Using de-emphasis can help to optimize the transmitted output signal; however, it will add to the power consumption.

The output edge speed can be set to slow mode of operation through the TXSLOW bit (bit 4 of [register 13](#)). For transmitter modulation output settings (TXMOD - [register 12](#)) below 0xC0 it is recommended to set TXSLOW = 1 to reduce the output jitter.

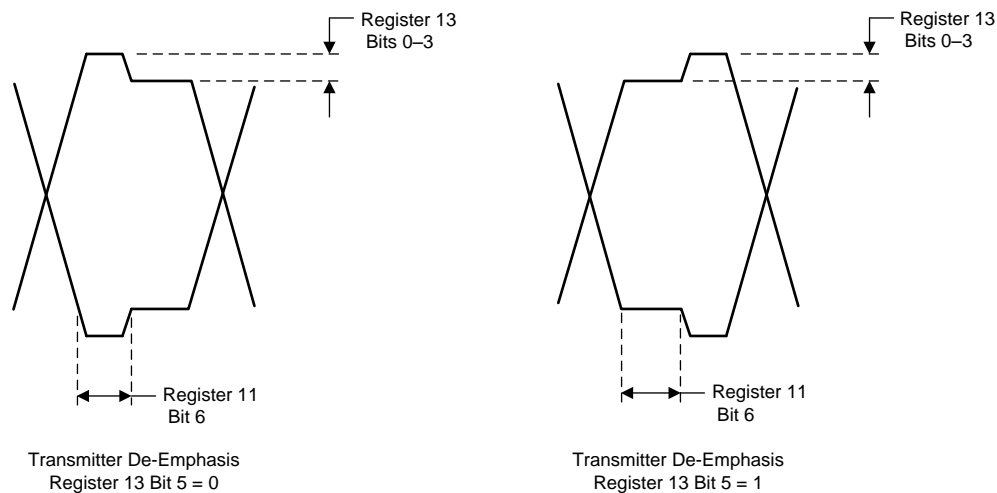


Figure 23. Transmitter De-Emphasis Modes

7.3.4 Modulation Current Generator

The modulation current generator provides the current for the high speed output driver described above. The circuit can be digitally controlled through the 2-wire interface block or controlled by applying an analog voltage in the range of 0 to 2 V to the AMP pin. The default method of control is through the 2-wire interface. To use the AMP pin set the transmitter amplitude control bit TXAMPCTRL = 1 (bit 0 of [register 10](#)).

An 8-bit wide control bus, TXMOD[0..7] ([register 12](#)), is used to set the desired modulation current and the output voltage.

The entire transmitter signal path, including CDR, can be disabled and powered down by setting TX_DIS = 1 (bit 7 of [register 10](#)).

Feature Description (continued)

7.3.5 DC Offset Cancellation and Cross Point Control

The ONET1131EC transmitter has DC offset cancellation to compensate for internal offset voltages. The offset cancellation can be disabled by setting TXOC_DIS = 1 (bit 2 of [register 10](#)).

The crossing point can be moved toward the one level by setting TXCPSGN = 1 (bit 7 of [register 14](#)) and it can be moved toward the zero level by setting TXCPSGN = 0. The percentage of shift depends upon the register settings of the transmitter cross-point adjustment bits TXCPADJ[0..6] ([register 14](#)).

7.3.6 Bias Current Generation and APC Loop

The bias current for the laser is turned off by default and has to be enabled by setting the laser bias current enable bit TXBIASEN = 1 (bit 2 of [register 1](#)). In open loop operation, selected by setting TXOLENA = 1 (bit 4 of [register 1](#)), the bias current is set directly by the 10-bit wide control word TXBIAS[0..9] ([register 15](#) and [register 16](#)). In Automatic Power Control (APC) mode, selected by setting TXOLENA = 0, the bias current depends on the register settings TXBIAS[0..9] and the coupling ratio (CR) between the laser bias current and the photodiode current. $CR = I_{BIAS}/I_{PD}$. If the photodiode cathode is connected to VCC and the anode is connected to the PD pin (PD pin is sinking current) set TXPDPOL = 1 (bit 0 of [register 1](#)). If the photodiode anode is connected to ground and the cathode is connected to the PD pin (PD pin is sourcing current), set TXPDPOL = 0.

Three photodiode current ranges can be selected by means of the photodiode current range bits TXPDRNG[0..1] (bits 5 and 6 of [register 1](#)). The photodiode range should be chosen to keep the laser bias control DAC, TXBIAS[0..9], close to the center of its range. This keeps the laser bias current set point resolution high. For details regarding the bias current setting in open-loop mode as well as in closed-loop mode, see the [Register Mapping](#) table.

The ONET1131EC has the ability to source or sink the bias current. The default condition is for the BIAS pin to source the current (TXBIASPOL = 0). To act as a sink, set TXBIASPOL = 1 (bit 1 of [register 1](#)).

The bias current is monitored using a current mirror with a gain equal to 1/100. By connecting a resistor between MONB and GND, the bias current can be monitored as a voltage across the resistor. A low temperature coefficient precision resistor should be used. The bias current can also be monitored as a 10 bit unsigned digital word by setting the transmitter bias current digital monitor selection bit TXDMONB = 1 (bit 5 of [register 16](#)) and removing the resistor from MONB to ground.

The photodiode current is monitored using a current mirror with various gains that are dependent upon the photodiode current range being used. By connecting a resistor between MONP and GND, the photodiode current can be monitored as a voltage across the resistor. A low temperature coefficient precision resistor should be used. The photodiode current can also be monitored as a 10 bit unsigned digital word by setting the transmitter photodiode current digital monitor selection bit TXDMONP = 1 (bit 6 of [register 16](#)) and removing the resistor from MONP to ground.

7.3.7 Laser Safety Features and Fault Recovery Procedure

The ONET1131EC provides built in laser safety features. The following fault conditions are detected if the transmitter fault detection enable bit TXFLTEN = 1 (bit 3 of [register 1](#)):

1. Voltage at MONB exceeds the bandgap voltage (1.2 V) or, alternately, if TXDMONB = 1 and the bias current exceeds the bias current monitor fault threshold set by TXBMF[0..7] ([register 17](#)). When using the digital monitor, the resistor from the MONB pin to ground must be removed.
2. Voltage at MONP exceeds the bandgap voltage (1.2 V) and the analog photodiode current monitor fault trigger bit, TXMONPFLT (bit 7 of [register 1](#)), is set to 1. Alternately, a fault can be triggered if TXDMONP = 1 and the photodiode current exceeds the photodiode current monitor fault threshold set by TXPMF[0..7] ([register 18](#)). When using the digital monitor, the resistor from the MONP pin to ground must be removed.
3. Photodiode current exceeds 150% of its set value,
4. Bias control DAC drops in value by more than 50% in one step.

If the fault detection is being used then to avoid a fault from occurring at start-up it is recommended to set up the required bias current and APC loop conditions first and enable the laser bias current (TXBIASEN = 1) as the last step in the sequence of commands.

Feature Description (continued)

If one or more fault conditions occur and the transmitter fault enable bit TXFLTEN is set to 1, the ONET1131EC responds by:

1. Setting the bias current to zero.
2. Asserting and latching the TX_FLT pin.
3. Setting the TX_FLT bit (bit 5 of [register 43](#)) to 1.

Fault recovery is performed by the following procedure:

1. The transmitter disable pin TX_DIS and/or the transmitter bias current enable bit TXBIASEN are toggled for at least the fault latch reset time.
2. The TX_FLT pin de-asserts while the transmitter disable pin TX_DIS is asserted or the transmitter bias current enable bit TXBIASEN is de-asserted.
3. If the fault condition is no longer present, the part returns to normal operation with its prior output settings after the disable negate time.
4. If the fault condition is still present, TX_FLT re-asserts once TX_DIS is set to a low level and/or TXBIASEN is set to 0 and the part will not return to normal operation.

7.3.8 Analog Block

7.3.8.1 Analog Reference and Temperature Sensor

The ONET1131EC is supplied by a single 2.5 V $\pm 5\%$ supply voltage connected to the VCC and VDD pins. This voltage is referred to ground (GND) and can be monitored as a 10 bit unsigned digital word through the 2-wire interface.

On-chip bandgap voltage circuitry generates a reference voltage, independent of the supply voltage, from which all other internally required voltages and bias currents are derived.

In order to minimize the module component count, the ONET1131EC provides an on-chip temperature sensor. The temperature can be monitored as a 10 bit unsigned digital word through the 2-wire interface.

7.3.8.2 Power-On Reset

The ONET1131EC has power on reset circuitry which ensures that all registers are reset to default values during startup. After the power-on to initialize time (t_{INIT1}), the internal registers are ready to be loaded. The part is ready to transmit data after the initialize to transmit time (t_{INIT2}), assuming that the enable chip bit EN_CHIP = 1 (bit 0 of [register 0](#)). In addition, the disable pin DIS must be set to zero.

The ONET1131EC bias current can be disabled by setting the DIS pin high. The internal registers are not reset. After the transmitter disable pin DIS is set low the part returns to its prior output settings.

7.3.8.3 Analog to Digital Converter

The ONET1131EC has an internal 10 bit analog to digital converter (ADC) that converts the analog monitors for temperature, power supply voltage, bias current and photodiode current into a 10 bit unsigned digital word. The first 8 most significant bits (MSBs) are available in [register 40](#) and the 2 least significant bits (LSBs) are available in [register 41](#). Depending on the accuracy required, 8 bits or 10 bits can be read. However, due to the architecture of the 2-wire interface, in order to read the 2 registers, 2 separate read commands have to be sent.

The ADC is enabled by default so to monitor a particular parameter, select the parameter with ADCSEL[0..2] (bits 0 to 2 of [register 3](#)). [Table 1](#) shows the ADCSEL bits and the parameter that is monitored.

Table 1. ADC Selection Bits and the Monitored Parameter

| ADCSEL2 | ADCSEL1 | ADCSEL0 | MONITORED PARAMETER |
|---------|---------|---------|---------------------|
| 0 | 0 | 0 | Temperature |
| 0 | 0 | 1 | Supply voltage |
| 0 | 1 | 0 | Bias current |
| 0 | 1 | 1 | Photodiode current |

To digitally monitor the photodiode current, ensure that TXDMONP = 1 (bit 6 of [register 16](#)) and that a resistor is not connected to the MONP pin. To digitally monitor the bias current, ensure that TXDMONB = 1 (bit 5 of [register 16](#)) and that a resistor is not connected to the MONB pin. The ADC is disabled by default. To enable the ADC, set the ADC oscillator enable bit OSCEN = 1 (bit 6 of [register 3](#)) and set the ADC enable bit ADCEN = 1 (bit 7 of [register 3](#)).

The digital word read from the ADC can be converted to its analog equivalent through the following formulas.

7.3.8.3.1 Temperature

$$\text{Temperature (}^{\circ}\text{C)} = (0.5475 \times \text{ADCx}) - 273 \quad (1)$$

7.3.8.3.2 Power Supply Voltage

$$\text{Power supply voltage (V)} = (1.36\text{m} \times \text{ADCx}) + 1.76 \quad (2)$$

7.3.8.3.3 Photodiode Current Monitor

$$\text{IPD}(\mu\text{A}) = 2 \times [(0.62 \times \text{ADCx}) - 16] \text{ for TXPDRNG00} \quad (3)$$

$$\text{IPD}(\mu\text{A}) = 4 \times [(0.62 \times \text{ADCx}) - 16] \text{ for TXPDRNG01} \quad (4)$$

$$\text{IPD}(\mu\text{A}) = 8 \times [(0.62 \times \text{ADCx}) - 16] \text{ for TXPDRNG1x} \quad (5)$$

7.3.8.3.4 Bias Current Monitor

$$\text{IBIAS (mA)} = (0.2 \times \text{ADCx}) - 4.5 \quad (6)$$

Where: ADCx = the decimal value read from the ADC

7.3.8.4 2-Wire Interface and Control Logic

The ONET1131EC uses a 2-wire serial interface for digital control. The two circuit inputs, SDA and SCK, are driven, respectively, by the serial data and serial clock from a microprocessor, for example. The SDA and SCK pins require external 4.7-k Ω to 10-k Ω pull-up resistor to VCC for proper operation.

The 2-wire interface allows write access to the internal memory map to modify control registers and read access to read out the control signals. The ONET1131EC is a slave device only which means that it cannot initiate a transmission itself; it always relies on the availability of the SCK signal for the duration of the transmission. The master device provides the clock signal as well as the START and STOP commands. The protocol for a data transmission is as follows:

1. START command
2. Seven (7) bit slave address (0001000) followed by an eighth bit which is the data direction bit (R/W). A zero indicates a WRITE and a 1 indicates a READ.
3. 8 bit register address
4. 8 bit register data word
5. STOP command

Regarding timing, the ONET1131EC is I²C compatible. The typical timing is shown in [Figure 2](#) and a complete data transfer is shown in [Figure 24](#). Parameters for [Figure 2](#) are defined in the [Timing Diagram Definitions](#).

7.3.8.5 Bus Idle

Both SDA and SCK lines remain HIGH

7.3.8.6 Start Data Transfer

A change in the state of the SDA line, from HIGH to LOW, while the SCK line is HIGH, defines a START condition (S). Each data transfer is initiated with a START condition.

7.3.8.7 Stop Data Transfer

A change in the state of the SDA line from LOW to HIGH while the SCK line is HIGH defines a STOP condition (P). Each data transfer is terminated with a STOP condition; however, if the master still wishes to communicate on the bus, it can generate a repeated START condition and address another slave without first generating a STOP condition.

7.3.8.8 Data Transfer

Only one data byte can be transferred between a START and a STOP condition. The receiver acknowledges the transfer of data.

7.3.9 Acknowledge

Each receiving device, when addressed, is obliged to generate an acknowledge bit. The transmitter releases the SDA line and a device that acknowledges must pull down the SDA line during the acknowledge clock pulse in such a way that the SDA line is stable LOW during the HIGH period of the acknowledge clock pulse. Setup and hold times must be taken into account. When a slave-receiver doesn't acknowledge the slave address, the data line must be left HIGH by the slave. The master can then generate a STOP condition to abort the transfer. If the slave-receiver does acknowledge the slave address but some time later in the transfer cannot receive any more data bytes, the master must abort the transfer. This is indicated by the slave generating the not acknowledge on the first byte to follow. The slave leaves the data line HIGH and the master generates the STOP condition, see [Figure 2](#).

7.4 Device Functional Modes

The ONET1131EC has two main functional modes of operation: differential transmitter output and single-ended transmitter output.

7.4.1 Differential Transmitter Output

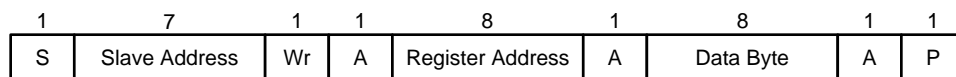
Operation with differential output is the default mode of operation. This mode is intended for externally modulated lasers requiring differential drive such as Mach Zehnder modulators.

7.4.2 Single-Ended Transmitter Output

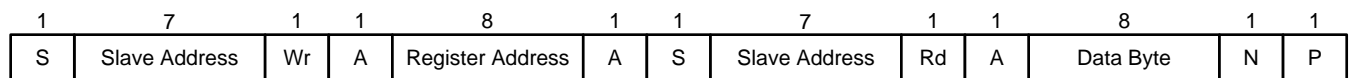
In order to reduce the power consumption for single-ended EML applications the output driver should be set to single-ended mode. The single-ended output signal can be enabled by setting the transmitter mode select bit TXMODE = 1 (bit 6 of [register 13](#)). The positive output is active by default. To enable the negative output and disable the positive output set TXOUTSEL = 1 (bit 7 of [register 13](#)).

7.5 Programming

Write Sequence



Read Sequence



Legend

| | |
|----|---------------------------|
| S | Start Condition |
| Wr | Write Bit (Bit Value = 0) |
| Rd | Read Bit (Bit Value = 1) |
| A | Acknowledge |
| N | Not Acknowledge |
| P | Stop Condition |

Figure 24. Programming Sequence

7.6 Register Mapping

7.6.1 R/W Control Registers

7.6.1.1 Core Level Register 0 (offset = 0100 0001 [reset = 41h])

Figure 25. Core Level Register 0

| 7 | 6 | 5 | 4 | 3 | 2 | 1 | 0 |
|---------------------|----------|---|---|---|-----------|---------|----|
| GLOBAL SW_PIN RESET | Reserved | | | | I2C RESET | EN_CHIP | |
| RWSC | RW | | | | RWSC | RWSC | RW |

LEGEND: R/W = Read/Write; R = Read only; -n = value after reset. RWSC = Read/Write self clearing (always reads back to zero)

Table 2. Core Level Register 0 Field Descriptions

| Bit | Field | Type | Reset | Description |
|-----|---------------------|------|-------|--|
| 7 | GLOBAL SW_PIN RESET | RWSC | 0 | Global Reset SW 1 = reset, resets all I2C and EEPROM modules to default 0 = normal operation (self-clearing, always reads back '0') |
| 6:3 | Reserved | R/W | 1 | Reserved |
| 2 | | RWSC | 0 | Reserved |
| 1 | I2C RESET | RWSC | 0 | Chip reset bit 1 = resets all I2C registers to default 0 = normal operation (self-clearing, always reads back '0') |
| 0 | EN_CHIP | R/W | 1 | Enable chip bit 1 = Chip enabled 0 = Chip disabled |

7.6.1.2 Core Level Register 1 (offset = 0000 0000) [reset = 0h]
Figure 26. Core Level Register 1

| 7 | 6 | 5 | 4 | 3 | 2 | 1 | 0 |
|-----------|----------|----------|---------|---------|----------|------------|--------|
| TXMONPFLT | TXPDRNG1 | TXPDRNG0 | TXOLENA | TXFLTEN | TXBIASEN | TTXBIASPOL | TXDPOL |
| R/W | R/W | R/W | R/W | R/W | R/W | R/W | R/W |

LEGEND: R/W = Read/Write; R = Read only; -n = value after reset

Table 3. Core Level Register 1 Field Descriptions

| Bit | Field | Type | Reset | Description |
|--------|----------------------|------|-------|---|
| 7 | TXMONPFLT | R/W | 0 | Analog photodiode current monitor fault trigger bit 1 = Fault trigger on MONP pin is enabled 0 = Fault trigger on MONP pin is disabled |
| 6 5 | TXPDRNG1 TXPDRNG0 | R/W | 0 | Photodiode current range bits 1X: up to 3080 μ A / 3 μ A resolution 01: up to 1540 μ A / 1.5 μ A resolution 00: up to 770 μ A / 0.75 μ A resolution |
| 4 | TXOLENA | R/W | 0 | Open loop enable bit 1 = Open loop bias current control 0 = Closed loop bias current control |
| 3 | TXFLTEN | R/W | 0 | Fault detection enable bit 1 = Fault detection on 0 = Fault detection off |
| 2 | TXBIASEN | R/W | 0 | Laser Bias current enable bit 1 = Bias current enabled. Toggle to 0 to reset a fault condition. 0 = Bias current disabled |
| 1 | TXBIASPOL | R/W | 0 | Laser Bias current polarity bit 1 = Bias pin sinks current 0 = Bias pin sources current |
| 0 | TXDPOL | R/W | 0 | Photodiode polarity bit 1 = Photodiode cathode connected to V_{CC} 0 = Photodiode anode connected to GND |

7.6.1.3 Core Level Register 2 (offset = 0000 0000) [reset = 0h]
Figure 27. Core Level Register 2

| | | | | | | | |
|----------|---|---|---|---|---|---|---|
| 7 | 6 | 5 | 4 | 3 | 2 | 1 | 0 |
| Reserved | | | | | | | |
| R/W | | | | | | | |

LEGEND: R/W = Read/Write; R = Read only; -n = value after reset

Table 4. Core Level Register 2 Field Descriptions

| Bit | Field | Type | Reset | Description |
|-----|----------|------|-------|-------------|
| 7:0 | Reserved | R/W | 0 | Reserved |

7.6.1.4 Core Level Register 3 (offset = 0000 0000) [reset = 0h]
Figure 28. Core Level Register 3

| | | | | | | | |
|-------|-------|----------|--------|----------|---------|---------|---------|
| 7 | 6 | 5 | 4 | 3 | 2 | 1 | 0 |
| ADCEN | OSCEN | Reserved | ADCRST | Reserved | ADCSEL2 | ADCSEL1 | ADCSEL0 |
| R/W | R/W | R/W | R/W | R/W | R/W | R/W | R/W |

LEGEND: R/W = Read/Write; R = Read only; -n = value after reset

Table 5. Core Level Register 3 Field Descriptions

| Bit | Field | Type | Reset | Description |
|-----|----------|------|-------|---|
| 7 | ADCEN | R/W | 0h | ADC enabled bit 1 = ADC enabled 0 = ADC disabled |
| 6 | OSCEN | R/W | 0h | ADC oscillator bit 1 = Oscillator enabled 0 = Oscillator disabled |
| 5 | Reserved | R/W | 0h | Reserved |
| 4 | ADCRST | R/W | 0h | ADC reset 1 = ADC reset 0 = ADC no reset |
| 3 | Reserved | R/W | 0h | Reserved |
| 2 | ADCSEL2 | R/W | 0h | ADC input selection bits <2:0> 000 selects the temperature sensor 001 selects the power supply monitor 010 selects IMONB 011 selects IMONP 1XX are reserved |
| 1 | ADCSEL1 | R/W | 0h | |
| 0 | ADCSEL0 | R/W | 0h | |

7.6.2 TX Registers

7.6.2.1 TX Register 10 (offset = 0000 0000) [reset = 0h]

Figure 29. TX Register 10

| 7 | 6 | 5 | 4 | 3 | 2 | 1 | 0 |
|--------|-----------|----------|-----------|----------|----------|----------|-----------|
| TX_DIS | TXOUT_DIS | TXOUTPOL | TXCDR_DIS | TX_CDRBP | TXOC_DIS | TXEQ_DIS | TXAMPCTRL |
| R/W | R/W | R/W | R/W | R/W | R/W | R/W | R/W |

LEGEND: R/W = Read/Write; R = Read only; -n = value after reset

Table 6. TX Register 10 Field Descriptions

| Bit | Field | Type | Reset | Description |
|-----|-----------|------|-------|--|
| 7 | TX_DIS | R/W | 0 | TX disable bit 1 = TX disabled (power-down) 0 = TX enabled |
| 6 | TXOUT_DIS | R/W | 0 | TX Output Driver disable bit 1 = output disabled 0 = output enabled |
| 5 | TXOUTPOL | R/W | 0 | TX Output polarity switch bit 1 = inverted polarity 0 = normal polarity |
| 4 | TXCDR_DIS | R/W | 0 | TX CDR disable bit 1 = TX CDR is disabled and bypassed 0 = TX CDR is enabled |
| 3 | TX_CDRBP | R/W | 0 | TX CDR bypass bit 1 = TX-CDR bypassed. 0 = TX-CDR not bypassed |
| 2 | TXOC_DIS | R/W | 0 | TX OC disable bit 1 = TX Offset Cancellation disabled 0 = TX Offset Cancellation enabled |
| 1 | TXEQ_DIS | R/W | 0 | TX Equalizer disable bit 1 = TX Equalizer is disabled and bypassed 0 = TX Equalizer is enabled |
| 0 | TXAMPCTRL | R/W | 0 | TX AMP Ctrl 1 = TX AMP Control is enabled (analog amplitude control) 0 = TX AMP Control is disabled (digital amplitude control) |

7.6.2.2 TX Register 11 (offset = 0000 0000) [reset = 0h]
Figure 30. TX Register 11

| 7 | 6 | 5 | 4 | 3 | 2 | 1 | 0 |
|----------|---------|----------|----------|---------|---------|---------|---------|
| TXAMPRNG | TXPKSEL | TXTCSEL1 | TXTCSEL0 | TXCTLE3 | TXCTLE2 | TXCTLE1 | TXCTLE0 |
| R/W | R/W | R/W | R/W | R/W | R/W | R/W | R/W |

LEGEND: R/W = Read/Write; R = Read only; -n = value after reset

Table 7. TX Register 11 Field Descriptions

| Bit | Field | Type | Reset | Description |
|-----|----------|------|-------|--|
| 7 | TXAMPRNG | R/W | 0 | TX output AMP range 1 = Half TX output amplitude range 0 = Full TX output amplitude range |
| 6 | TXPKSEL | R/W | 0 | TX output peaking width 1 = wide peaking width 0 = narrow peaking width |
| 5 | TXTCSEL1 | R/W | 0 | TXOUT temperature compensation select bit 1 |
| 4 | TXTCSEL0 | R/W | 0 | TXOUT temperature compensation select bit 0 |
| 3 | TXCTLE3 | R/W | 0 | TX input CTLE setting 0000 = minimum 1111 = maximum |
| 2 | TXCTLE2 | R/W | 0 | |
| 1 | TXCTLE1 | R/W | 0 | |
| 0 | TXCTLE0 | R/W | 0 | |

7.6.2.3 TX Register 12 (offset = 0000 0000) [reset = 0h]
Figure 31. TX Register 12

| 7 | 6 | 5 | 4 | 3 | 2 | 1 | 0 |
|--------|--------|--------|--------|--------|--------|--------|--------|
| TXMOD7 | TXMOD6 | TXMOD5 | TXMOD4 | TXMOD3 | TXMOD2 | TXMOD1 | TXMOD0 |
| R/W | R/W | R/W | R/W | R/W | R/W | R/W | R/W |

LEGEND: R/W = Read/Write; R = Read only; -n = value after reset

Table 8. TX Register 12 Field Descriptions

| Bit | Field | Type | Reset | Description |
|-----|--------|------|-------|---|
| 7 | TXMOD7 | R/W | 0 | TX Modulation current setting: sets the output voltage Output Voltage: 2.4 Vpp / 9.5 mVpp steps |
| 6 | TXMOD6 | R/W | 0 | |
| 5 | TXMOD5 | R/W | 0 | |
| 4 | TXMOD4 | R/W | 0 | |
| 3 | TXMOD3 | R/W | 0 | |
| 2 | TXMOD2 | R/W | 0 | |
| 1 | TXMOD1 | R/W | 0 | |
| 0 | TXMOD0 | R/W | 0 | |

7.6.2.4 TX Register 13 (offset = 0h) [reset = 0]
Figure 32. TX Register 13

| 7 | 6 | 5 | 4 | 3 | 2 | 1 | 0 |
|----------|--------|--------|--------|----------|----------|----------|----------|
| TXOUTSEL | TXMODE | TXSTEP | TXSLOW | TXDEADJ3 | TXDEADJ2 | TXDEADJ1 | TXDEADJ0 |
| R/W | R/W | R/W | R/W | R/W | R/W | R/W | R/W |

LEGEND: R/W = Read/Write; R = Read only; -n = value after reset

Table 9. TX Register 13 Field Descriptions

| Bit | Field | Type | Reset | Description |
|-----|----------|------|-------|--|
| 7 | TXOUTSEL | R/W | 0 | TX output selection bit 1 = The negative output TXOUT– is active 0 = The positive output TXOUT+ is active |
| 6 | TXMODE | R/W | 0 | TX output mode selection bit 1 = Single-ended mode 0 = Differential mode |
| 5 | TXSTEP | R/W | 0 | TX output de-emphasis mode selection bit 1 = Delayed de-emphasis 0 = Normal de-emphasis |
| 4 | TXSLOW | R/W | 0 | TX edge speed selection bit 1 = Slow edge speed 0 = Normal operation |
| 3 | TXDEADJ3 | R/W | 0 | TX de-emphasis setting 0000 = minimum 1111 = maximum |
| 2 | TXDEADJ2 | R/W | 0 | |
| 1 | TXDEADJ1 | R/W | 0 | |
| 0 | TXDEADJ0 | R/W | 0 | |

7.6.2.5 TX Register 14 (offset = 0000 0000) [reset = 0h]
Figure 33. TX Register 14

| 7 | 6 | 5 | 4 | 3 | 2 | 1 | 0 |
|---------|----------|----------|----------|----------|----------|----------|----------|
| TXCPSGN | TXCPADJ6 | TXCPADJ5 | TXCPADJ4 | TXCPADJ3 | TXCPADJ2 | TXCPADJ1 | TXCPADJ0 |
| R/W | R/W | R/W | R/W | R/W | R/W | R/W | R/W |

LEGEND: R/W = Read/Write; R = Read only; -n = value after reset

Table 10. TX Register 14 Field Descriptions

| Bit | Field | Type | Reset | Description |
|-----|----------|------|-------|--|
| 7 | TXCPSGN | R/W | 0 | TX Eye cross-point adjustment setting TXCPSGN = 1 (positive shift) Maximum shift for 1111111 Minimum shift for 0000000 TXCPSGN = 0 (negative shift) Maximum shift for 1111111 Minimum shift for 0000000 |
| 6 | TXCPADJ6 | R/W | 0 | |
| 5 | TXCPADJ5 | R/W | 0 | |
| 4 | TXCPADJ4 | R/W | 0 | |
| 3 | TXCPADJ3 | R/W | 0 | |
| 2 | TXCPADJ2 | R/W | 0 | |
| 1 | TXCPADJ1 | R/W | 0 | |
| 0 | TXCPADJ0 | R/W | 0 | |

7.6.2.6 TX Register 15 (offset = 0000 0000) [reset = 0h]
Figure 34. TX Register 15

| 7 | 6 | 5 | 4 | 3 | 2 | 1 | 0 |
|---------|---------|---------|---------|---------|---------|---------|---------|
| TXBIAS9 | TXBIAS8 | TXBIAS7 | TXBIAS6 | TXBIAS5 | TXBIAS4 | TXBIAS3 | TXBIAS2 |
| R/W | R/W | R/W | R/W | R/W | R/W | R/W | R/W |

LEGEND: R/W = Read/Write; R = Read only; -n = value after reset

Table 11. TX Register 15 Field Descriptions

| Bit | Field | Type | Reset | Description |
|-----|---------|------|-------|--|
| 7 | TXBIAS9 | R/W | 0 | Bias current settings (8MSB; 2LSBs are in register 16) Closed loop (APC): Coupling ratio $CR = I_{BIAS} / I_{PD}$, $TXBIAS = 0..1023$, $I_{BIAS} \leq 150$ mA: TXPDRNG = 00; $I_{BIAS} = 0.75 \mu A \times CR \times TXBIAS$ TXPDRNG = 01; $I_{BIAS} = 1.5 \mu A \times CR \times TXBIAS$ TXPDRNG = 1X; $I_{BIAS} = 3 \mu A \times CR \times TXBIAS$ Open Loop: $I_{BIAS} \sim 147 \mu A \times TXBIAS$ in source mode $I_{BIAS} \sim 147 \mu A \times TXBIAS$ in sink mode |
| 6 | TXBIAS8 | R/W | 0 | |
| 5 | TXBIAS7 | R/W | 0 | |
| 4 | TXBIAS6 | R/W | 0 | |
| 3 | TXBIAS5 | R/W | 0 | |
| 2 | TXBIAS4 | R/W | 0 | |
| 1 | TXBIAS3 | R/W | 0 | |
| 0 | TXBIAS2 | R/W | 0 | |

7.6.2.7 TX Register 16 (offset = 0000 0000) [reset = 0h]
Figure 35. TX Register 16

| 7 | 6 | 5 | 4 | 3 | 2 | 1 | 0 |
|----------|---------|---------|----------|-----|-----|---------|---------|
| Reserved | TXDMONP | TXDMONB | Reserved | | | TXBIAS1 | TXBIAS1 |
| R/W | R/W | R/W | R/W | R/W | R/W | R/W | R/W |

LEGEND: R/W = Read/Write; R = Read only; -n = value after reset

Table 12. TX Register 16 Field Descriptions

| Bit | Field | Type | Reset | Description |
|-----|----------|------|-------|--|
| 7 | Reserved | R/W | 0 | Reserved |
| 6 | TXDMONP | R/W | 0 | Digital photodiode current monitor selection bit (MONP) 1 = Digital photodiode monitor is active (no external resistor is needed) 0 = Analog photodiode monitor is active (external resistor is required) |
| 5 | TXDMONB | R/W | 0 | Digital bias current monitor selection bit (MONB) 1 = Digital bias current monitor is active (no external resistor is needed) 0 = Analog bias current monitor is active (external resistor is required) |
| 4:2 | Reserved | R/W | 0 | Reserved |
| 1 | TXBIAS1 | R/W | 0 | Laser Bias current setting (2 LSBs) |
| 0 | TXBIAS0 | R/W | 0 | |

7.6.2.8 TX Register 17 (offset = 0000 0000) [reset = 0h]
Figure 36. TX Register 17

| 7 | 6 | 5 | 4 | 3 | 2 | 1 | 0 |
|--------|--------|--------|--------|--------|--------|--------|--------|
| TXBMF7 | TXBMF6 | TXBMF5 | TXBMF4 | TXBMF3 | TXBMF2 | TXBMF1 | TXBMF0 |
| R/W | R/W | R/W | R/W | R/W | R/W | R/W | R/W |

LEGEND: R/W = Read/Write; R = Read only; -n = value after reset

Table 13. TX Register 17 Field Descriptions

| Bit | Field | Type | Reset | Description |
|-----|--------|------|-------|---|
| 7 | TXBMF7 | R/W | 0 | Bias current monitor fault threshold With TXDMONB = 1 Register sets the value of the bias current that will trigger a fault. The external resistor on the MONB pin must be removed to use this feature. |
| 6 | TXBMF6 | R/W | 0 | |
| 5 | TXBMF5 | R/W | 0 | |
| 4 | TXBMF4 | R/W | 0 | |
| 3 | TXBMF3 | R/W | 0 | |
| 2 | TXBMF2 | R/W | 0 | |
| 1 | TXBMF1 | R/W | 0 | |
| 0 | TXBMF0 | R/W | 0 | |

7.6.2.9 TX Register 18 (offset = 0000 0000) [reset = 0h]
Figure 37. TX Register 18

| 7 | 6 | 5 | 4 | 3 | 2 | 1 | 0 |
|--------|--------|--------|--------|--------|--------|--------|--------|
| TXPMF7 | TXPMF6 | TXPMF5 | TXPMF4 | TXPMF3 | TXPMF2 | TXPMF1 | TXPMF0 |
| R/W | R/W | R/W | R/W | R/W | R/W | R/W | R/W |

LEGEND: R/W = Read/Write; R = Read only; -n = value after reset

Table 14. TX Register 18 Field Descriptions

| Bit | Field | Type | Reset | Description |
|-----|--------|------|-------|--|
| 7 | TXPMF7 | R/W | 0 | Power monitor fault threshold With TXDMONP = 1 Register sets the value of the photodiode current that will trigger a fault. The external resistor on the MONP pin must be removed to use this feature. |
| 6 | TXPMF6 | R/W | 0 | |
| 5 | TXPMF5 | R/W | 0 | |
| 4 | TXPMF4 | R/W | 0 | |
| 3 | TXPMF3 | R/W | 0 | |
| 2 | TXPMF2 | R/W | 0 | |
| 1 | TXPMF1 | R/W | 0 | |
| 0 | TXPMF0 | R/W | 0 | |

7.6.2.10 TX Register 19 (offset = 0000 0000) [reset = 0h]
Figure 38. TX Register 19

| 7 | 6 | 5 | 4 | 3 | 2 | 1 | 0 |
|-----------|-----------|---------|----------|-----------|--------|--------|--------|
| TXFD_MOD1 | TXFD_MOD0 | TXFD_EN | TXFD_DIS | 0TXFL_DIS | TXDIV2 | TXDIV1 | TXDIV0 |
| R/W | R/W | R/W | R/W | R/W | R/W | R/W | R/W |

LEGEND: R/W = Read/Write; R = Read only; -n = value after reset

Table 15. TX Register 19 Field Descriptions

| Bit | Field | Type | Reset | Description |
|-----|-----------|------|-------|--|
| 7 | TXFD_MOD1 | R/W | 0 | TX frequency detection mode selection 00 = auto selection enabled 01 = Pre-selected to 10.3 Gbps 10 = Pre-select to 11.1 Gbps 11 = test mode (do not use) |
| 6 | TXFD_MOD0 | R/W | 0 | |
| 5 | TXFD_EN | R/W | 0 | TX frequency detector enable bit 1 = TX frequency detector is always enabled 0 = TX frequency detector in automatic mode |
| 4 | TXFD_DIS | R/W | 0 | TX frequency detector disable bit 1 = TX frequency detector is always disabled 0 = TX frequency detector is in automatic mode |
| 3 | TXFL_DIS | R/W | 0 | TX CDR fast lock disable bit 1 = TX CDR fast lock disabled 0 = TX CDR in fast lock mode |
| 2 | TXDIV2 | R/W | 0 | TX Divider Ratio 000: Full-Rate, 001: Divide by 2 010: Divide by 4 011: Divide by 8 100: Divide by 16 101: Divide by 32 |
| 1 | TXDIV1 | R/W | 0 | |
| 0 | TXDIV0 | R/W | 0 | |

7.6.3 Reserved Registers

7.6.3.1 Reserved Registers 20-39

Figure 39. Reserved Registers 20-39

| | | | | | | | |
|----------|---|---|---|---|---|---|---|
| 7 | 6 | 5 | 4 | 3 | 2 | 1 | 0 |
| Reserved | | | | | | | |
| R | | | | | | | |

LEGEND: R/W = Read/Write; R = Read only; -n = value after reset

Table 16. Reserved Registers 20-39 Field Descriptions

| Bit | Field | Type | Reset | Description |
|-----|----------|------|-------|-------------|
| 7:0 | Reserved | R | 0 | Reserved |

7.6.4 Read Only Registers

7.6.4.1 Core Level Register 40 (offset = 0000 0000) [reset = 0h]

Figure 40. Core Level Register 40

| 7 | 6 | 5 | 4 | 3 | 2 | 1 | 0 |
|------|------|------|------|------|------|------|------|
| ADC9 | ADC8 | ADC5 | ADC4 | ADC3 | ADC2 | ADC1 | ADC0 |
| R | R | R | R | R | R | R | R |

LEGEND: R/W = Read/Write; R = Read only; -n = value after reset

Table 17. Core Level Register 40 Field Descriptions

| Bit | Field | Type | Reset | Description |
|-----|------------|------|-------|--|
| 7 | ADC9 (MSB) | R | 0 | Digital representation of the ADC input source (read only) |
| 6 | ADC8 | R | 0 | |
| 5 | ADC7 | R | 0 | |
| 4 | ADC6 | R | 0 | |
| 3 | ADC5 | R | 0 | |
| 2 | ADC4 | R | 0 | |
| 1 | ADC3 | R | 0 | |
| 0 | ADC2 | R | 0 | |

7.6.4.2 Core Level Register 41 (offset = 0000 0000) [reset = 0h]

Figure 41. Core Level Register 41

| 7 | 6 | 5 | 4 | 3 | 2 | 1 | 0 |
|----------|---|---|---|---|---|------|------|
| Reserved | | | | | | ADC1 | ADC0 |
| R | | | | | | R | R |

LEGEND: R/W = Read/Write; R = Read only; -n = value after reset

Table 18. Core Level Register 41 Field Descriptions

| Bit | Field | Type | Reset | Description |
|-----|------------|------|-------|--|
| 7:2 | Resereved | R | 0h | Reserved |
| 1 | ADC1 | R | 0h | Digital representation of the ADC input source (read only) |
| 0 | ADC0 (LSB) | R | 0h | |

7.6.4.3 TX Register 43 (offset = 0000 0000) [reset = 0h]
Figure 42. Core Level Register 43

| 7 | 6 | 5 | 4 | 3 | 2 | 1 | 0 |
|-----------|-----------|--------|-----------|----------|---|---|---|
| TXCDRLock | TXCDRLock | TX_FLT | TX_DRVDIS | Reserved | | | |
| R | R | R | R | R | | | |

LEGEND: R/W = Read/Write; R = Read only; -n = value after reset; RCLR = Read clear

Table 19. TX Registers 43 Field Descriptions

| Bit | Field | Type | Reset | Description |
|-----|-------------------------|------|-------|--|
| 7 | TXCDRLock | R | 0 | TX CDR lock status bit 1 = TX CDR is not locked 0 = TX CDR is locked |
| 6 | TXCDRLock (latched Low) | RCLR | 0 | Latched low status of bit 7. Cleared when read. Latched low bit set to 0 when raw status goes low and keep it low even if raw status goes high. |
| 5 | TX_FLT | R | 0 | TX fault status bit 1 = TX fault detected 0 = TX fault not detected |
| 4 | TX_DRVDIS | R | 0 | TX driver disable status bit 1 = TX fault logic disables the driver 0 = TX fault logic does not disable the driver |
| 3:0 | Reserved | R | 0 | Reserved |

7.6.5 Adjustment Registers

7.6.5.1 Adjustment Registers 44-50

Figure 43. Adjustment Registers 44-50

| | | | | | | | |
|----------|---|---|---|---|---|---|---|
| 7 | 6 | 5 | 4 | 3 | 2 | 1 | 0 |
| Reserved | | | | | | | |
| R | | | | | | | |

LEGEND: R/W = Read/Write; R = Read only; -n = value after reset

Table 20. Adjustment Registers 44-50 Field Descriptions

| Bit | Field | Type | Reset | Description |
|-----|----------|------|-------|-------------|
| 7:0 | Reserved | R | 0 | Reserved |

7.6.5.2 Adjustment Register 51 (offset = 0100 0000) [reset = 40h]

Figure 44. Adjustment Register 51

| | | | | | | | |
|-----------|-----------|-----------|----------|---|---|---|---|
| 7 | 6 | 5 | 4 | 3 | 2 | 1 | 0 |
| SEL_RES_2 | SEL_RES_1 | SEL_RES_0 | Reserved | | | | |
| R | R | R | R | | | | |

LEGEND: R/W = Read/Write; R = Read only; -n = value after reset

Table 21. Adjustment Register 51 Field Descriptions

| Bit | Field | Type | Reset | Description |
|-----|-----------|------|-------|--|
| 7 | SEL_RES_2 | R/W | 0 | CDR Loop Filter Resistor 000: 75, 001: 150 010: 225 011: 300 100: 375 101: 450 110: 525 111: 600 Default = 225 |
| 6 | SEL_RES_1 | R/W | 1 | |
| 5 | SEL_RES_0 | R/W | 0 | |
| 4:0 | Reserved | R/W | 0 | |

7.6.5.3 Adjustment Registers 52-55

Figure 45. Adjustment Registers 52-55

| | | | | | | | |
|----------|---|---|---|---|---|---|---|
| 7 | 6 | 5 | 4 | 3 | 2 | 1 | 0 |
| Reserved | | | | | | | |
| R | | | | | | | |

LEGEND: R/W = Read/Write; R = Read only; -n = value after reset

Table 22. Adjustment Registers 52-55 Field Descriptions

| Bit | Field | Type | Reset | Description |
|-----|----------|------|-------|-------------|
| 7:0 | Reserved | R | 0 | Reserved |

8 Application Information and Implementations

NOTE

Information in the following applications sections is not part of the TI component specification, and TI does not warrant its accuracy or completeness. TI's customers are responsible for determining suitability of components for their purposes. Customers should validate and test their design implementation to confirm system functionality.

8.1 Application Information

The ONET1131EC is designed to be used in conjunction with a Transmitter Optical Sub-Assembly (TOSA). The ONET1131EC, TOSA, microcontroller and power management circuitry will typically be used in an XFP or SFP+ 10 Gbps optical transceiver. Figure 46 shows the ONET1131EC in differential mode of operation modulating a differentially driven Mach Zehnder (MZ) modulator TOSA and Figure 48 and Figure 49 show the device in single-ended output mode with an Electroabsorptive Modulated Laser (EML) TOSA. Figure 48 has the photodiode cathode available and Figure 49 has the photodiode anode available.

8.2 Typical Application, Transmitter Differential Mode

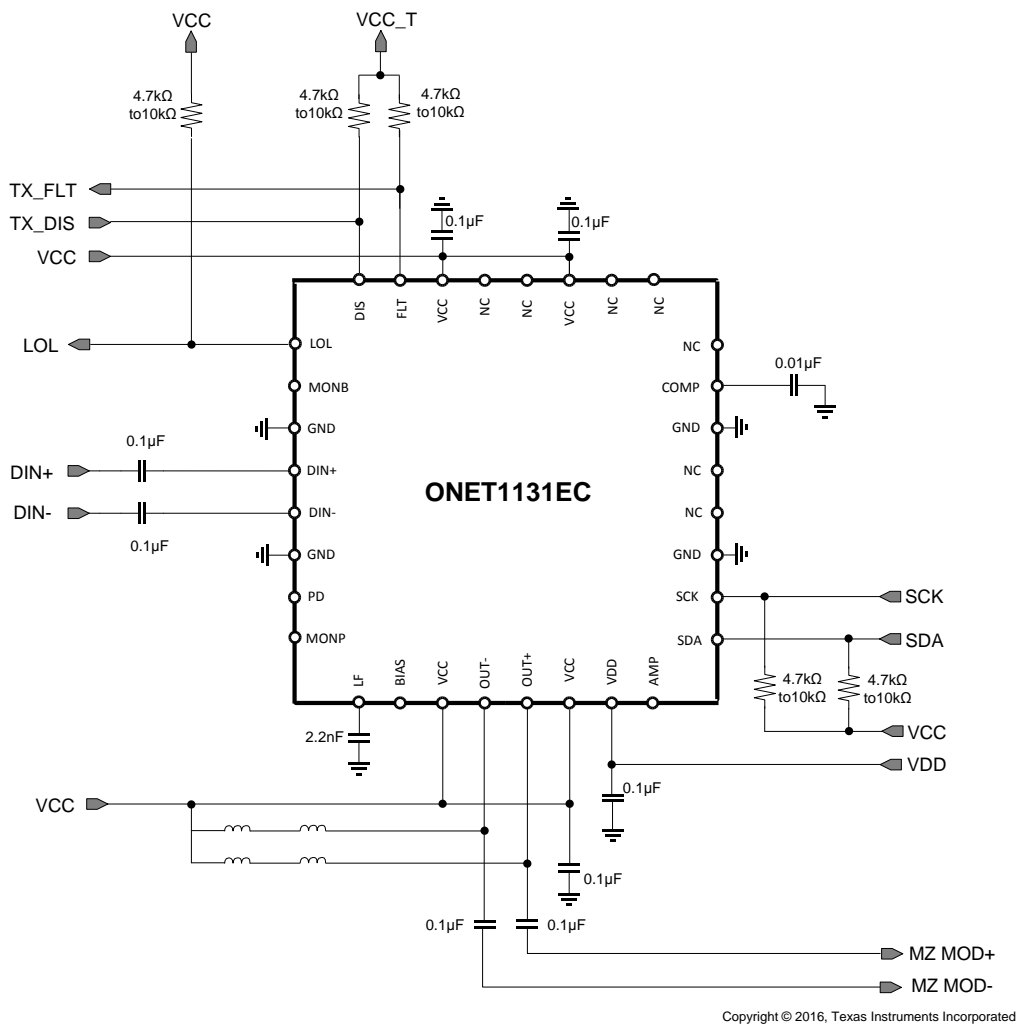


Figure 46. Typical Application Circuit in Differential Mode

Typical Application, Transmitter Differential Mode (continued)

8.2.1 Design Requirements

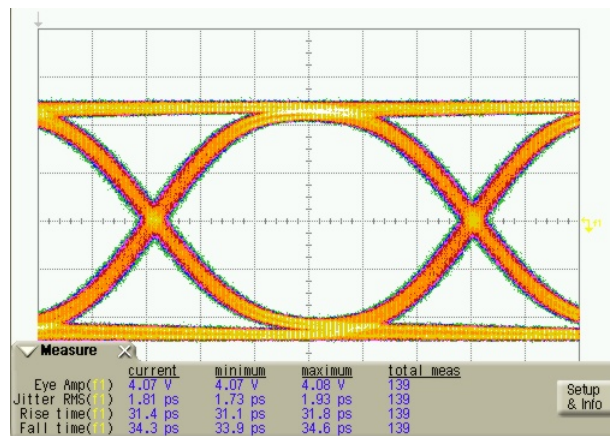
Table 23. Design Parameters

| PARAMETER | VALUE |
|----------------------------|------------------------------------|
| Supply voltage | 2.5 V |
| Transmitter input voltage | 100 mVpp to 1000 mVpp differential |
| Transmitter output voltage | 1 Vpp to 3.6 Vpp differential |

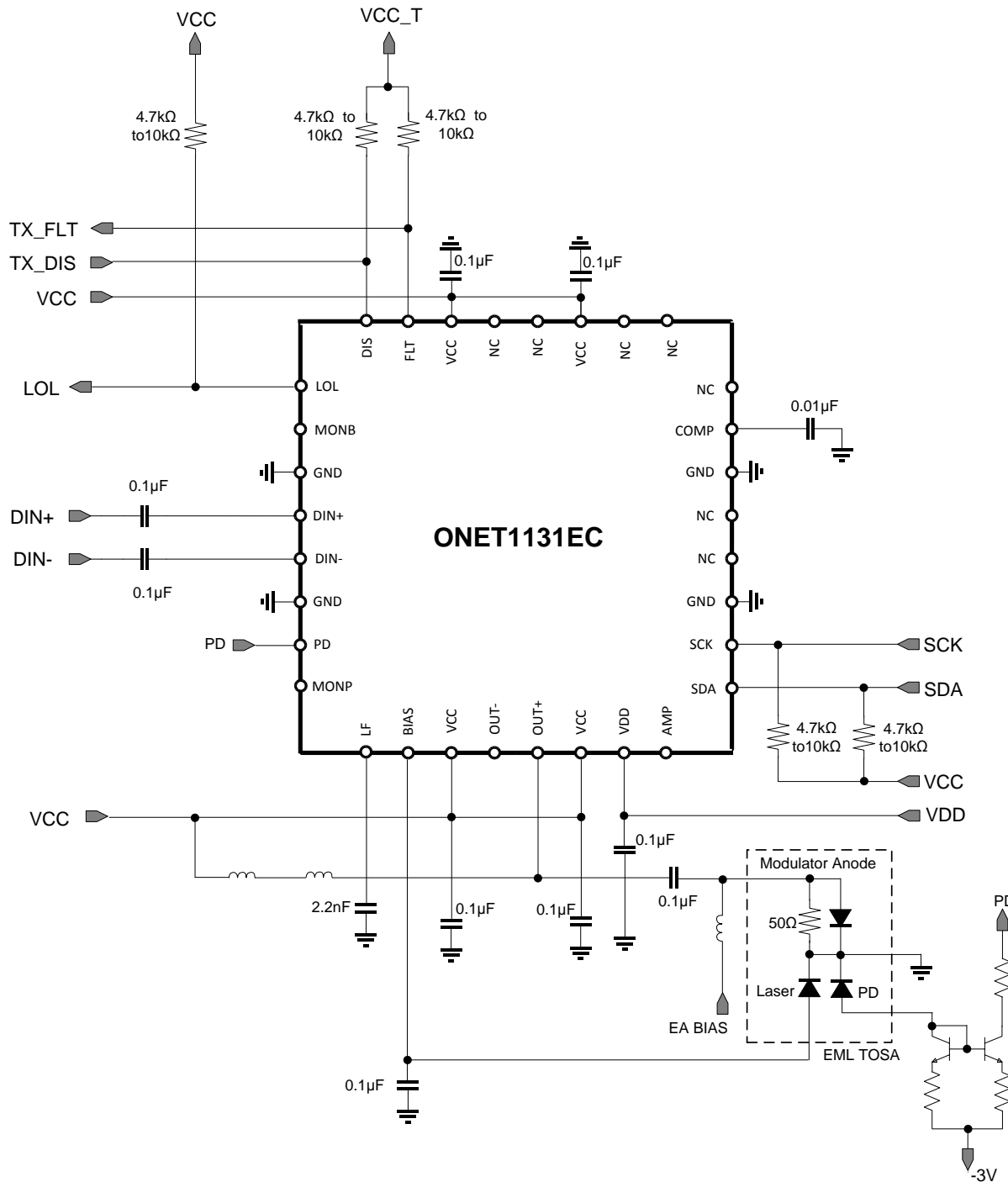
8.2.2 Detailed Design Procedure

In the transmitter differential mode of operation, the output driver is intended to be used with a differentially driven Mach Zehnder (MZ) modulator TOSA. On the input side, the DIN+ and DIN- pins are required to be AC coupled to the signal from the host system and the input voltage should be between 100 mVpp and 1000 mVpp differential. On the output side, the OUT+ pin is AC coupled to the modulator positive input and the OUT- pin is AC coupled to the modulator negative input. A bias-T from VCC to both the OUT+ and OUT- pins is required to supply sufficient headroom voltage for the output driver transistors. It is recommended that the inductance in the bias-T have low DC resistance to limit the DC voltage drop and maximize the voltage supplied to the OUT+ and OUT- pins. If the voltage on these pins drops below approximately 2.1 V then the output rise and fall times can be adversely affected.

8.2.3 Application Curve

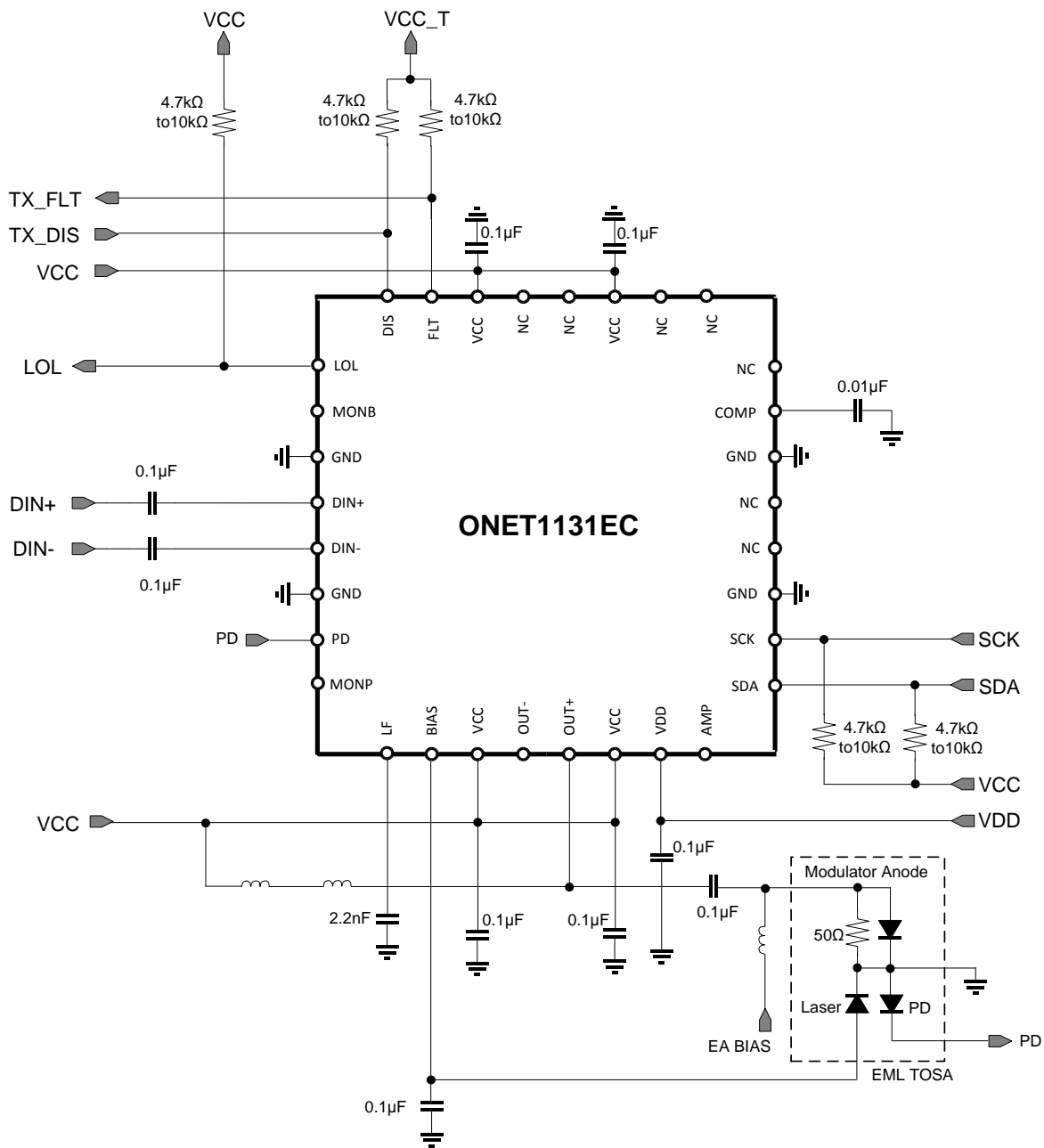

Figure 47. Differential Mode Transmitter Output Eye Diagram

8.2.4 Typical Application, Transmitter Single-Ended Mode



Copyright © 2016, Texas Instruments Incorporated

Figure 48. Typical Application Circuit in Single-Ended Mode with an EML and the PD Monitor Cathode Available



Copyright © 2016, Texas Instruments Incorporated

Figure 49. Typical Application Circuit in Single-Ended Mode with an EML and the PD Monitor Anode Available

8.2.4.1 Design Requirements

Table 24. Design Parameters

| PARAMETER | VALUE |
|----------------------------|------------------------------------|
| Supply voltage | 2.5 V |
| Transmitter input voltage | 100 mVpp to 1000 mVpp differential |
| Transmitter output voltage | 0.5 Vpp to 2 Vpp single-ended |

8.2.4.2 Detailed Design Procedure

In the transmitter single-ended mode of operation, the output driver is intended to be used with a single-ended driven Electroabsorptive Modulated Laser (EML) TOSA. On the input side, the DIN+ and DIN– pins are required to be AC coupled to the signal from the host system and the input voltage should be between 100 mVpp and 1000 mVpp differential. On the output side, it is recommended that the OUT+ pin is AC coupled to the modulator input and the OUT– pin can be left unterminated or terminated to VCC through a 50-Ω resistor. A bias-T from VCC to the OUT+ pin is required to supply sufficient headroom voltage for the output driver transistors. It is recommended that the inductance in the bias-T have low DC resistance to limit the DC voltage drop and maximize the voltage supplied to the TXOUT+ pin. If the voltage on this pins drops below approximately 2.1V then the output rise and fall times can be adversely affected.

8.2.4.3 Application Curves

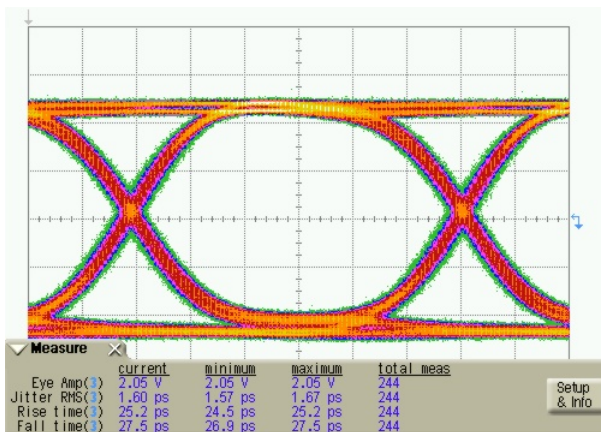


Figure 50. Single-Ended Mode Transmitter Output Eye Diagram

9 Power Supply Recommendations

The ONET1131EC is designed to operate from an input supply voltage range between 2.37 V and 2.63 V. To reduce digital coupling into the analog circuitry, there are separate supplies for the transmitter, and digital circuitry. VCC is used to supply power to the transmitter, and VDD is used to supply power to the digital block. Power supply decoupling capacitors should be placed as close as possible to the respective power supply pins.

10 Layout

10.1 Layout Guidelines

For optimum performance, use 50-Ω transmission lines (100-Ω differential) for connecting the high speed inputs and outputs. The length of transmission lines should be kept as short as possible to reduce loss and pattern-dependent jitter.

If the single-ended mode of operation is being used (TXMODE = 1) then it is recommended to terminate the unused output with a 50-Ω resistor to VCC. [Figure 51](#) shows a typical layout for the high speed inputs and outputs.

10.2 Layout Example

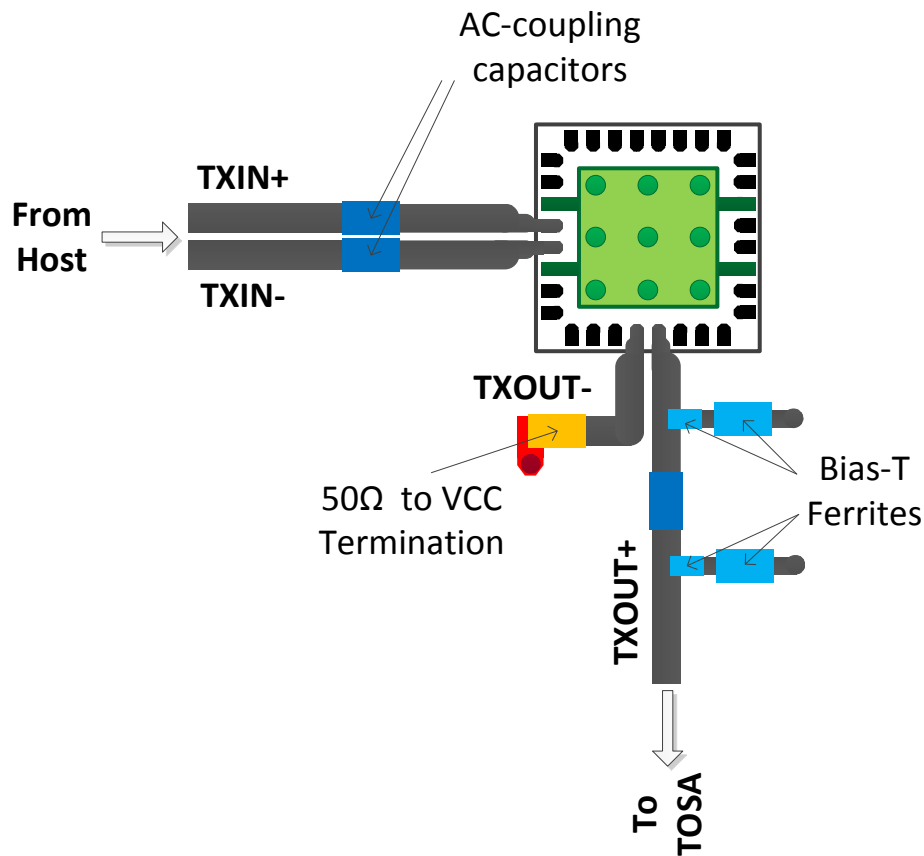


Figure 51. Board Layout

11 Device and Documentation Support

11.1 Receiving Notification of Documentation Updates

To receive notification of documentation updates, navigate to the device product folder on ti.com. In the upper right corner, click on Alert me to register and receive a weekly digest of any product information that has changed. For change details, review the revision history included in any revised document.

11.2 Community Resources

The following links connect to TI community resources. Linked contents are provided "AS IS" by the respective contributors. They do not constitute TI specifications and do not necessarily reflect TI's views; see TI's [Terms of Use](#).

TI E2E™ Online Community *TI's Engineer-to-Engineer (E2E) Community*. Created to foster collaboration among engineers. At e2e.ti.com, you can ask questions, share knowledge, explore ideas and help solve problems with fellow engineers.

Design Support *TI's Design Support* Quickly find helpful E2E forums along with design support tools and contact information for technical support.

11.3 Trademarks

E2E is a trademark of Texas Instruments.
All other trademarks are the property of their respective owners.

11.4 Electrostatic Discharge Caution



These devices have limited built-in ESD protection. The leads should be shorted together or the device placed in conductive foam during storage or handling to prevent electrostatic damage to the MOS gates.

11.5 Glossary



[SLYZ022](#) — *TI Glossary*.

This glossary lists and explains terms, acronyms, and definitions.

12 Mechanical, Packaging, and Orderable Information

The following pages include mechanical, packaging, and orderable information. This information is the most current data available for the designated devices. This data is subject to change without notice and revision of this document. For browser-based versions of this data sheet, refer to the left-hand navigation.

PACKAGING INFORMATION

| Orderable Device | Status (1) | Package Type | Package Drawing | Pins | Package Qty | Eco Plan (2) | Lead finish/ Ball material (6) | MSL Peak Temp (3) | Op Temp (°C) | Device Marking (4/5) | Samples |
|------------------|---------------|--------------|-----------------|------|-------------|-----------------|--------------------------------------|----------------------|--------------|-------------------------|---|
| ONET1131ECRSMR | ACTIVE | VQFN | RSM | 32 | 3000 | RoHS & Green | NIPDAU | Level-2-260C-1 YEAR | -40 to 100 | ONET 1131EC |  |
| ONET1131ECRSMT | ACTIVE | VQFN | RSM | 32 | 250 | RoHS & Green | NIPDAU | Level-2-260C-1 YEAR | -40 to 100 | ONET 1131EC |  |

(1) The marketing status values are defined as follows:

ACTIVE: Product device recommended for new designs.

LIFEBUY: TI has announced that the device will be discontinued, and a lifetime-buy period is in effect.

NRND: Not recommended for new designs. Device is in production to support existing customers, but TI does not recommend using this part in a new design.

PREVIEW: Device has been announced but is not in production. Samples may or may not be available.

OBSOLETE: TI has discontinued the production of the device.

(2) **RoHS:** TI defines "RoHS" to mean semiconductor products that are compliant with the current EU RoHS requirements for all 10 RoHS substances, including the requirement that RoHS substance do not exceed 0.1% by weight in homogeneous materials. Where designed to be soldered at high temperatures, "RoHS" products are suitable for use in specified lead-free processes. TI may reference these types of products as "Pb-Free".

RoHS Exempt: TI defines "RoHS Exempt" to mean products that contain lead but are compliant with EU RoHS pursuant to a specific EU RoHS exemption.

Green: TI defines "Green" to mean the content of Chlorine (Cl) and Bromine (Br) based flame retardants meet JS709B low halogen requirements of <=1000ppm threshold. Antimony trioxide based flame retardants must also meet the <=1000ppm threshold requirement.

(3) MSL, Peak Temp. - The Moisture Sensitivity Level rating according to the JEDEC industry standard classifications, and peak solder temperature.

(4) There may be additional marking, which relates to the logo, the lot trace code information, or the environmental category on the device.

(5) Multiple Device Markings will be inside parentheses. Only one Device Marking contained in parentheses and separated by a "~" will appear on a device. If a line is indented then it is a continuation of the previous line and the two combined represent the entire Device Marking for that device.

(6) Lead finish/Ball material - Orderable Devices may have multiple material finish options. Finish options are separated by a vertical ruled line. Lead finish/Ball material values may wrap to two lines if the finish value exceeds the maximum column width.

Important Information and Disclaimer:The information provided on this page represents TI's knowledge and belief as of the date that it is provided. TI bases its knowledge and belief on information provided by third parties, and makes no representation or warranty as to the accuracy of such information. Efforts are underway to better integrate information from third parties. TI has taken and continues to take reasonable steps to provide representative and accurate information but may not have conducted destructive testing or chemical analysis on incoming materials and chemicals. TI and TI suppliers consider certain information to be proprietary, and thus CAS numbers and other limited information may not be available for release.

In no event shall TI's liability arising out of such information exceed the total purchase price of the TI part(s) at issue in this document sold by TI to Customer on an annual basis.

TAPE AND REEL INFORMATION



QUADRANT ASSIGNMENTS FOR PIN 1 ORIENTATION IN TAPE



*All dimensions are nominal

| Device | Package Type | Package Drawing | Pins | SPQ | Reel Diameter (mm) | Reel Width W1 (mm) | A0 (mm) | B0 (mm) | K0 (mm) | P1 (mm) | W (mm) | Pin1 Quadrant |
|----------------|--------------|-----------------|------|------|--------------------|--------------------|---------|---------|---------|---------|--------|---------------|
| ONET1131ECRSMR | VQFN | RSM | 32 | 3000 | 330.0 | 12.4 | 4.25 | 4.25 | 1.15 | 8.0 | 12.0 | Q2 |
| ONET1131ECRSMT | VQFN | RSM | 32 | 250 | 180.0 | 12.4 | 4.25 | 4.25 | 1.15 | 8.0 | 12.0 | Q2 |

TAPE AND REEL BOX DIMENSIONS


*All dimensions are nominal

| Device | Package Type | Package Drawing | Pins | SPQ | Length (mm) | Width (mm) | Height (mm) |
|----------------|--------------|-----------------|------|------|-------------|------------|-------------|
| ONET1131ECRSMR | VQFN | RSM | 32 | 3000 | 367.0 | 367.0 | 35.0 |
| ONET1131ECRSMT | VQFN | RSM | 32 | 250 | 210.0 | 185.0 | 35.0 |

GENERIC PACKAGE VIEW

RSM 32

VQFN - 1 mm max height

4 x 4, 0.4 mm pitch

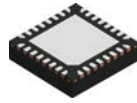
PLASTIC QUAD FLATPACK - NO LEAD

This image is a representation of the package family, actual package may vary.
Refer to the product data sheet for package details.



4224982/A

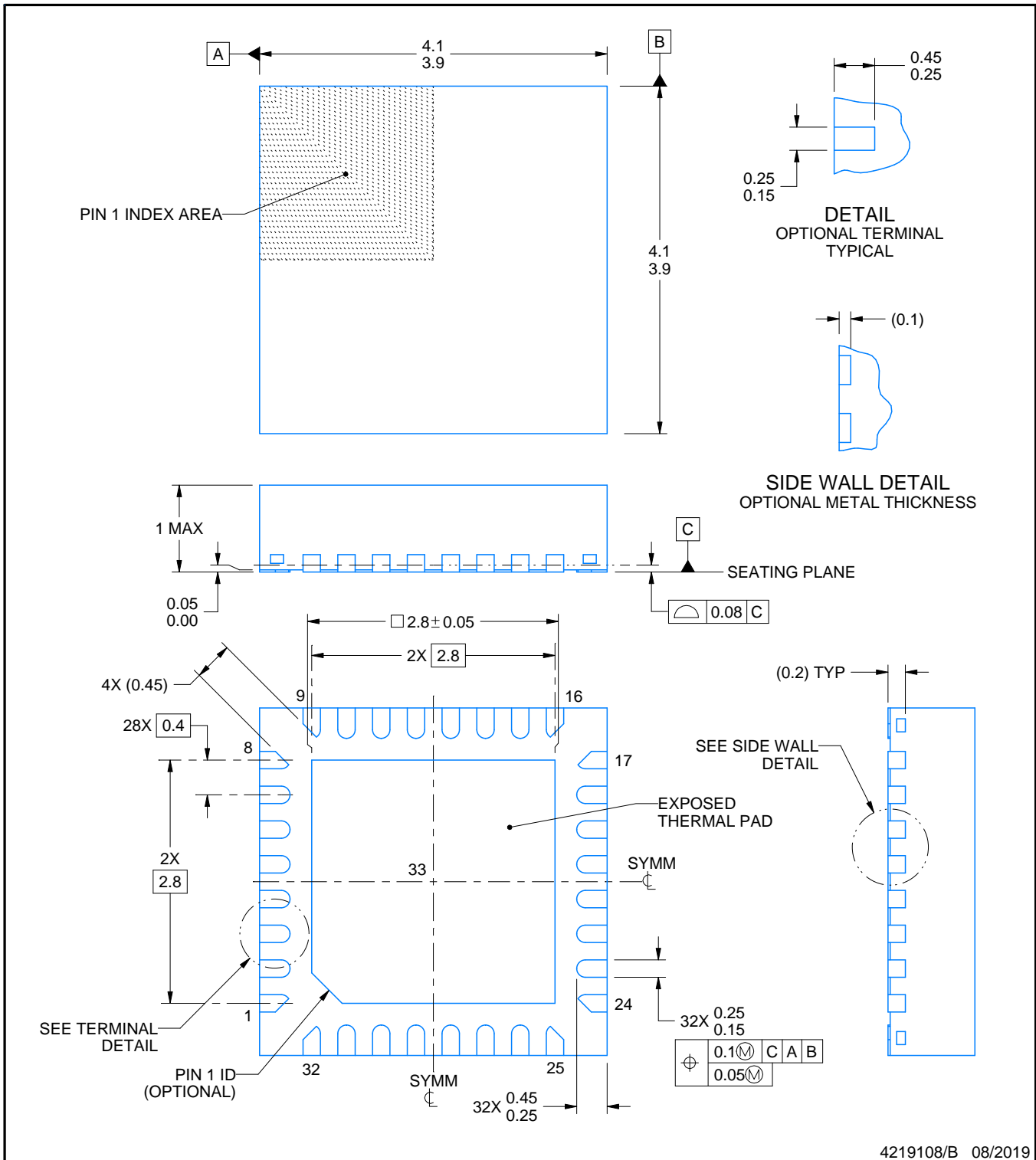
RSM0032B



PACKAGE OUTLINE

VQFN - 1 mm max height

PLASTIC QUAD FLATPACK - NO LEAD



4219108/B 08/2019

NOTES:

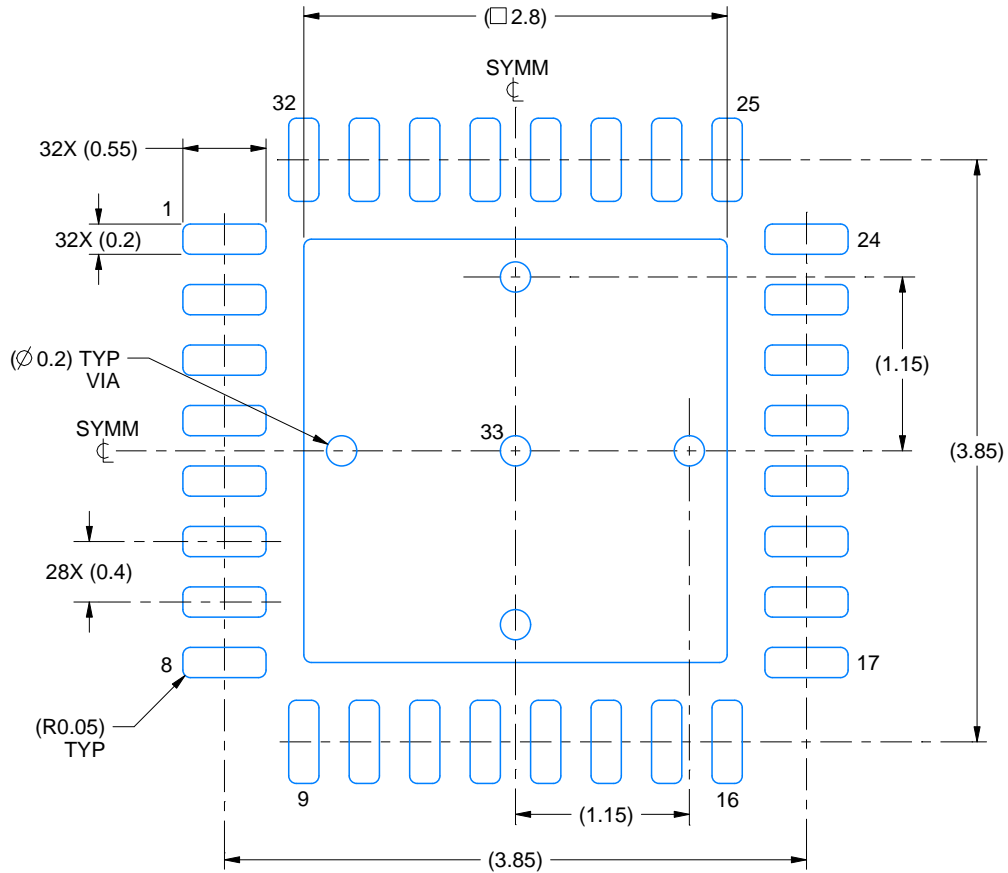
1. All linear dimensions are in millimeters. Any dimensions in parenthesis are for reference only. Dimensioning and tolerancing per ASME Y14.5M.
2. This drawing is subject to change without notice.
3. The package thermal pad must be soldered to the printed circuit board for thermal and mechanical performance.

EXAMPLE BOARD LAYOUT

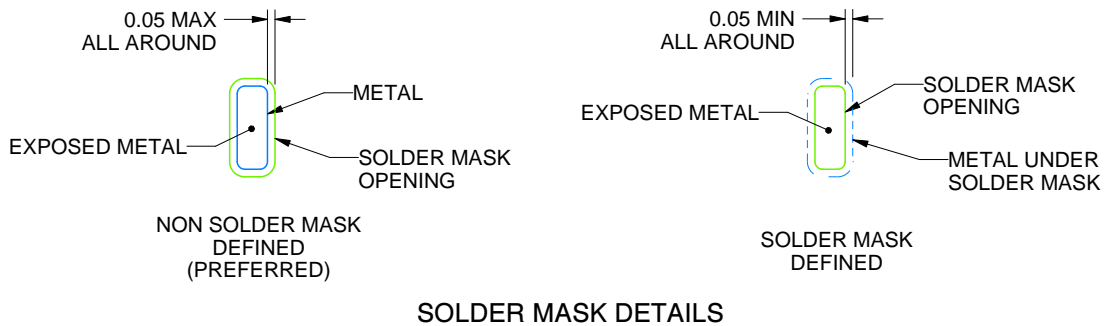
RSM0032B

VQFN - 1 mm max height

PLASTIC QUAD FLATPACK - NO LEAD



LAND PATTERN EXAMPLE
EXPOSED METAL SHOWN
SCALE:20X



SOLDER MASK DETAILS

4219108/B 08/2019

NOTES: (continued)

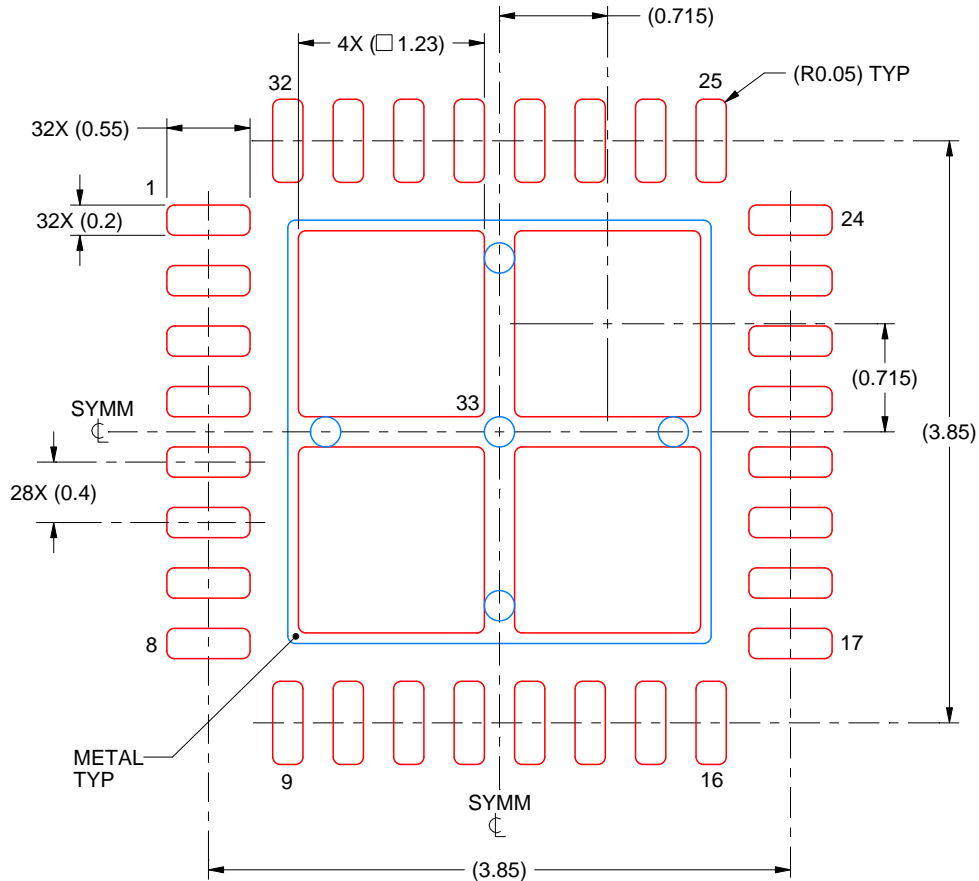
4. This package is designed to be soldered to a thermal pad on the board. For more information, see Texas Instruments literature number SLUA271 (www.ti.com/lit/sluea271).
5. Vias are optional depending on application, refer to device data sheet. If any vias are implemented, refer to their locations shown on this view. It is recommended that vias under paste be filled, plugged or tented.

EXAMPLE STENCIL DESIGN

RSM0032B

VQFN - 1 mm max height

PLASTIC QUAD FLATPACK - NO LEAD



SOLDER PASTE EXAMPLE
BASED ON 0.1 mm THICK STENCIL

EXPOSED PAD 33:
77% PRINTED SOLDER COVERAGE BY AREA UNDER PACKAGE
SCALE:20X

4219108/B 08/2019

NOTES: (continued)

6. Laser cutting apertures with trapezoidal walls and rounded corners may offer better paste release. IPC-7525 may have alternate design recommendations.

IMPORTANT NOTICE AND DISCLAIMER

TI PROVIDES TECHNICAL AND RELIABILITY DATA (INCLUDING DATASHEETS), DESIGN RESOURCES (INCLUDING REFERENCE DESIGNS), APPLICATION OR OTHER DESIGN ADVICE, WEB TOOLS, SAFETY INFORMATION, AND OTHER RESOURCES "AS IS" AND WITH ALL FAULTS, AND DISCLAIMS ALL WARRANTIES, EXPRESS AND IMPLIED, INCLUDING WITHOUT LIMITATION ANY IMPLIED WARRANTIES OF MERCHANTABILITY, FITNESS FOR A PARTICULAR PURPOSE OR NON-INFRINGEMENT OF THIRD PARTY INTELLECTUAL PROPERTY RIGHTS.

These resources are intended for skilled developers designing with TI products. You are solely responsible for (1) selecting the appropriate TI products for your application, (2) designing, validating and testing your application, and (3) ensuring your application meets applicable standards, and any other safety, security, or other requirements. These resources are subject to change without notice. TI grants you permission to use these resources only for development of an application that uses the TI products described in the resource. Other reproduction and display of these resources is prohibited. No license is granted to any other TI intellectual property right or to any third party intellectual property right. TI disclaims responsibility for, and you will fully indemnify TI and its representatives against, any claims, damages, costs, losses, and liabilities arising out of your use of these resources.

TI's products are provided subject to TI's Terms of Sale (www.ti.com/legal/termsofsale.html) or other applicable terms available either on ti.com or provided in conjunction with such TI products. TI's provision of these resources does not expand or otherwise alter TI's applicable warranties or warranty disclaimers for TI products.

Mailing Address: Texas Instruments, Post Office Box 655303, Dallas, Texas 75265
Copyright © 2020, Texas Instruments Incorporated