

PHYSICAL DIMENSIONS:

A	8.68 [.342]	± 0.25 [.010]
A1	9.55 [.376]	MAX
B	5.60 [.220]	± 0.10 [.004]
C	2.85 [.112]	± 0.07 [.003]
C1	3.80 [.150]	± MAX.
E	2.84 [.112]	± 0.10 [.004]

WIRE DIMENSIONS:

T1	1.75 [.069]	± 0.25 [.010]
T2	0.81 [.032]	REF.
T3	0.43 [.017]	REF.

CM3421Y600R-10

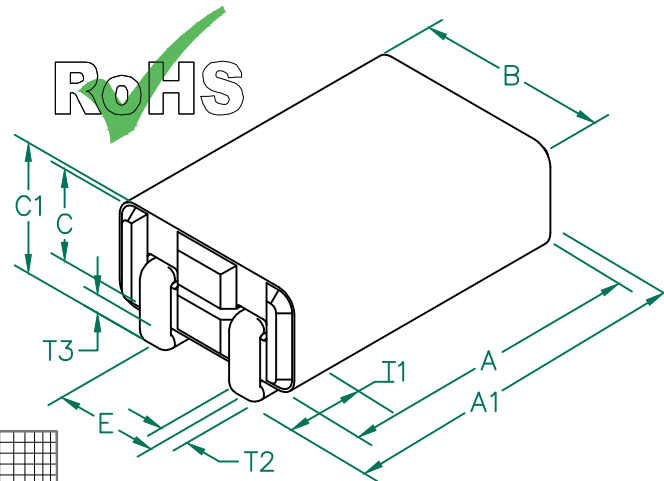

ELECTRICAL CHARACTERISTICS:

	Z in (Ω) @ 100 MHz	IR (MΩ) @ 500Vdc	DCR (Ω)	Rated Current (Continuous)	Rated Voltage (VDC)
Nom. (Ref.)	60				
Min.	45	100			
Max.	-		.00075	15,000 mA	140

NOTES: UNLESS OTHERWISE SPECIFIED

1. TAPED AND REELED per CURRENT EIA SPECS. 13" REELS, 2000 PCS PER REEL
2. COMPONENTS SHOULD BE ADEQUATELY PREHEATED BEFORE SOLDERING.
3. REF.CARRIER TAPE SPECIFICATION CART3421-1P.
4. THIS PART HAS NO PIN POLARITY.
5. TERMINATION FINISH IS 100% TIN.
6. OPERATION TEMPERATURE (INCLUDING SELF-HEATING): -40 ~ +125°C.
7. PART MUST BE HALOGEN-FREE.

Z vs. Frequency (C, N, O)

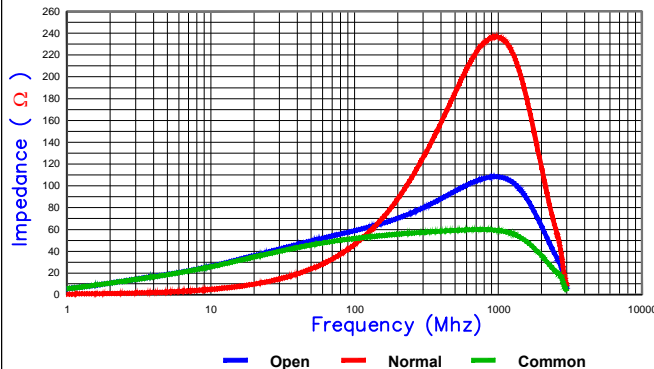

— Open — Normal — Common

Z, R, X vs. Frequency COMMON MODE

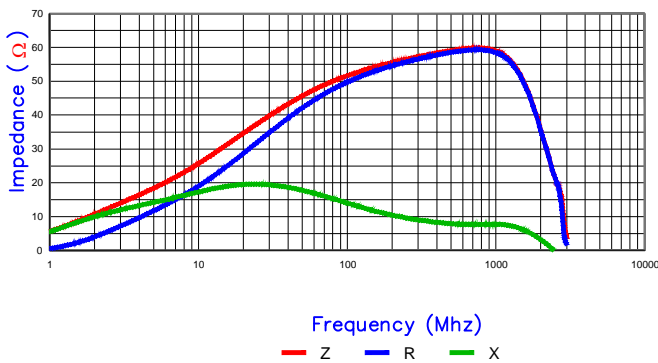

— Z — R — X

LAND PATTERNS FOR REFLOW SOLDERING

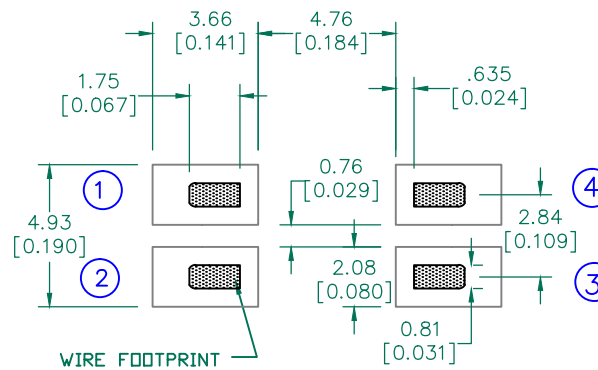

WIRE FOOTPRINT

EQUIVALENT CIRCUIT NO POLARITY

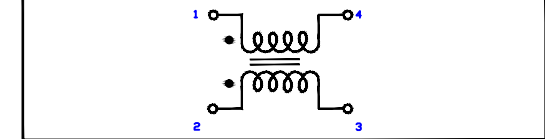

RECOMMENDED SOLDERING CONDITIONS

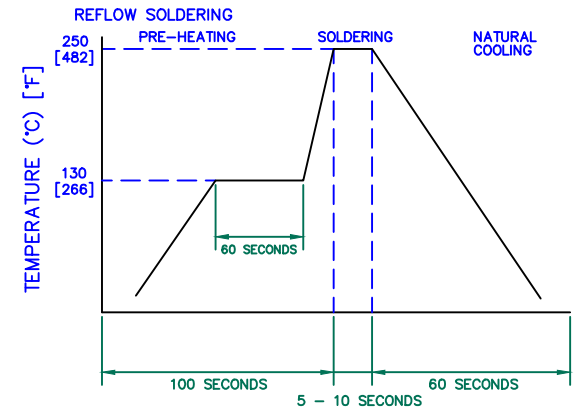

DIMENSIONS ARE IN mm [INCHES].				This print is the property of Laird Tech. and is loaned in confidence subject to return upon request and with the understanding that no copies shall be made without the written consent of Laird Tech. All rights to design or invention are reserved.	
J	ADD IR & RATED VOLTAGE & NOTE 6&7	07/22/14	QIU	REV	J
H	UPDATE NOTES 1 & 2	09/08/09	JRK	PART TYPE:	ASSEMBLY
G	UPDATE COMPANY LOGO	03/02/09	JRK	PROJECT/PART NUMBER:	CM3421Y600R-10
F	UPDATE COMPANY LOGO	11/28/07	JRK	DATE:	07/27/05
E	INTERCHANGE DIMENSIONS A,B&C	03/30/06	JRK	SCALE:	7 : 1
D	ADD EQUIVALENT CIRCUIT, REFLOW CHART	02/02/06	JRK	SHEET:	1 of 2
REV	DESCRIPTION	DATE	INT	GAD #	CM3421Y600R-10-J-1
				TOOL #	H0220



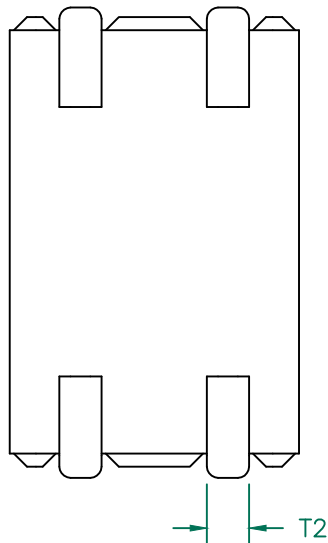
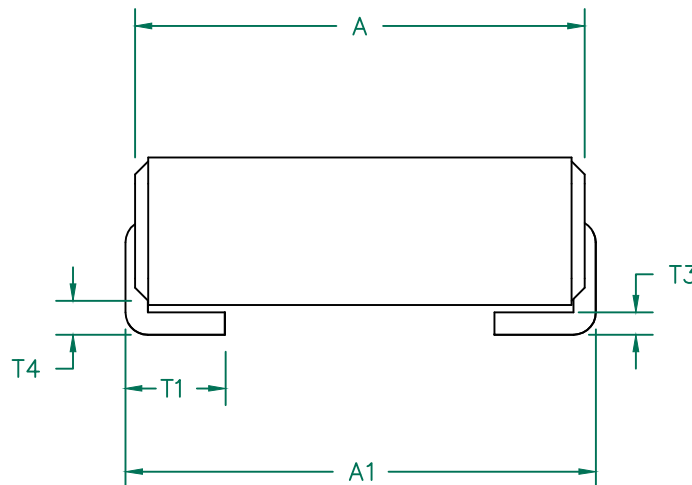
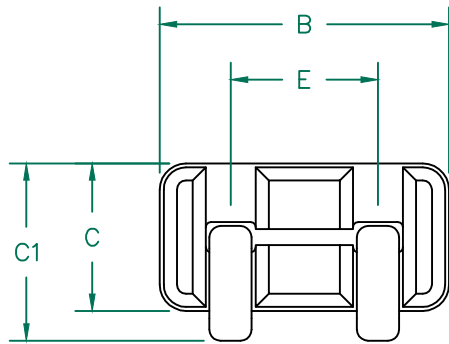

ELECTRICAL TESTING

TEST:	Z
# TURNS	1
AWG	-
FREQUENCY	100 MHz
NOMINAL (REF.)	33 Ω
MINIMUM	25 Ω
CORE WEIGHT/1000	.583 kgs. 1.286 Lbs.

DIMENSIONS:

A	8.68 [.342]	±	0.25 [.010]
A1	9.55 [.376]		MAX
B	5.60 [.220]	±	0.10 [.004]
C	2.85 [.112]	±	0.07 [.003]
C1	3.80 [.150]		MAX.
E	2.84 [.112]	±	0.10 [.004]

WIRE DIMENSIONS:

T ₁	1.75 [.069]	+	0.25 [.010]
T ₂	0.81 [.032]	+	REF.
T ₃	0.43 [.017]	+	REF.
T ₄	0.86 [.034]	+	MAX.

NOTES: UNLESS OTHERWISE SPECIFIED

1. IMPEDANCE VALUES ARE GROSS, MEASURED USING W2021-11 WIRE w/ NO D.C. BIAS.
2. REFERENCE STEWARD WIRE PURCHASE SPEC. W0021-11.
3. REFERENCE STEWARD CORE P/N 24H0220-110.
4. TERMINATION FINISH IS 100% TIN.

DIMENSIONS ARE IN mm [INCHES].				This print is the property of Laird Tech. and is loaned in confidence subject to return upon request and with the understanding that no copies shall be made without the written consent of Laird Tech. All rights to design or invention are reserved.		Laird	
J	ADD IR & RATED VOLTAGE & NOTE 6&7	07/22/14	JRK	QIU			
H	UPDATE NOTES 1 & 2	09/08/09	JRK				
G	UPDATE COMPANY LOGO ADD T2 DIMENSION TO ISO VIEW	03/02/09	JRK				
F	UPDATE COMPANY LOGO	11/28/07	JRK				
E	INTERCHANGE DIMENSIONS A,B&C ADD EQUIVALENT CIRCUIT, REFLOW CHART	03/30/06	JRK				
D	UPDATE BOTH CURVES ADD NEW TEST REF #	02/02/06	JRK				
REV	DESCRIPTION	DATE	INT				
PROJECT/PART NUMBER:				REV	PART TYPE:	DRAWN BY:	
CM3421Y600R-10				J	ASSEMBLY	JRK	
DATE: 07/27/05			SCALE: 7 : 1		SHEET:		
CAD # CM3421Y600R-10-J-2			TOOL # H0220		2 of 2		