

Description

ZXGD3105N8 synchronous controller is designed for driving a MOSFET as an ideal rectifier. This is to replace a diode for increasing the power transfer efficiency.

Proportional Gate drive control monitors the reverse voltage of the MOSFET such that if body diode conduction occurs a positive voltage is applied to the MOSFET's Gate Pin. Once the positive voltage is applied to the Gate the MOSFET switches on allowing reverse current flow. The controllers' output voltage is then proportional to the MOSFET Drain-Source voltage and this is applied to the Gate via the driver. This action minimizes body diode conduction whilst enabling a rapid MOSFET turn-off as the Drain current decays to zero.

Applications

Flyback Converters in:

- Low Voltage AC- DC Adaptors
- Set-Top-Box
- PoE Power Devices

Resonant Converters in:

- Telecoms PSU
- Laptop Adaptors
- Computing Power Supplies – ATX and Server PSU

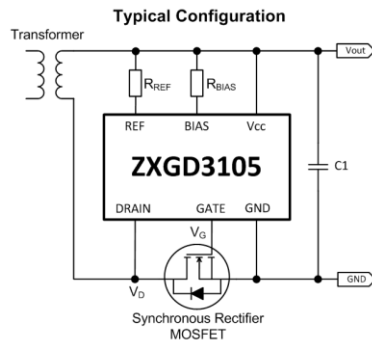

Features

- Proportional Gate Drive to Minimize Body Diode Conduction
- Low Standby Power with Quiescent Supply Current <1mA
- 4.5V Operation Enables Low Voltage Supply
- 25V V_{CC} Rating
- 100V Drain Voltage Rating
- Operation up to 500kHz
- Critical Conduction Mode (CrCM) & Continuous Mode (CCM)
- Compliant with Eco-Design Directive
- **Totally Lead-Free & Fully RoHS compliant (Notes 1 & 2)**
- **Halogen and Antimony free. "Green" Device (Note 3)**
- **Qualified to AEC-Q101 Standards for High Reliability**

Mechanical Data

- Case: SO-8
- Case Material: Molded Plastic. "Green" Molding Compound. UL Flammability Classification Rating 94V-0
- Moisture Sensitivity: Level 1 per J-STD-020
- Terminals: Finish – Matte Tin Plated Leads, Solderable per MIL-STD-202, Method 208 (E3)
- Weight: 0.074 grams (Approximate)

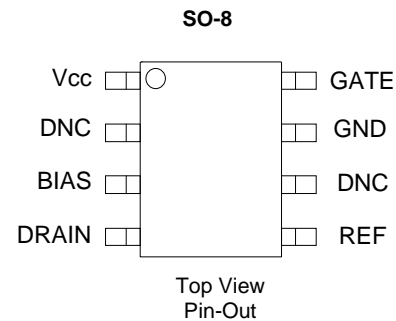

Ordering Information (Note 4)

Product	Marking	Reel Size (inches)	Tape Width (mm)	Quantity per Reel
ZXGD3105N8TC	ZXGD3105	13	12	2,500

- Notes:
1. No purposely added lead. Fully EU Directive 2002/95/EC (RoHS) & 2011/65/EU (RoHS 2) compliant.
 2. See http://www.diodes.com/quality/lead_free.html for more information about Diodes Incorporated's definitions of Halogen and Antimony free, "Green" and Lead-Free.
 3. Halogen and Antimony free "Green" products are defined as those which contain <900ppm bromine, <900ppm chlorine (<1500ppm total Br + Cl) and <1000ppm antimony compounds.
 4. For packaging details, go to our website at <http://www.diodes.com/products/packages.html>.

Marking Information

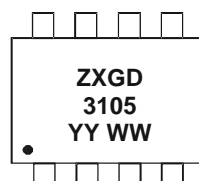

- ZXGD = Product Type Marking Code, Line 1
- 3105 = Product Type Marking Code, Line 2
- YY = Year (ex: 11 = 2011)
- WW = Week (01 - 53)

Functional Block Diagram

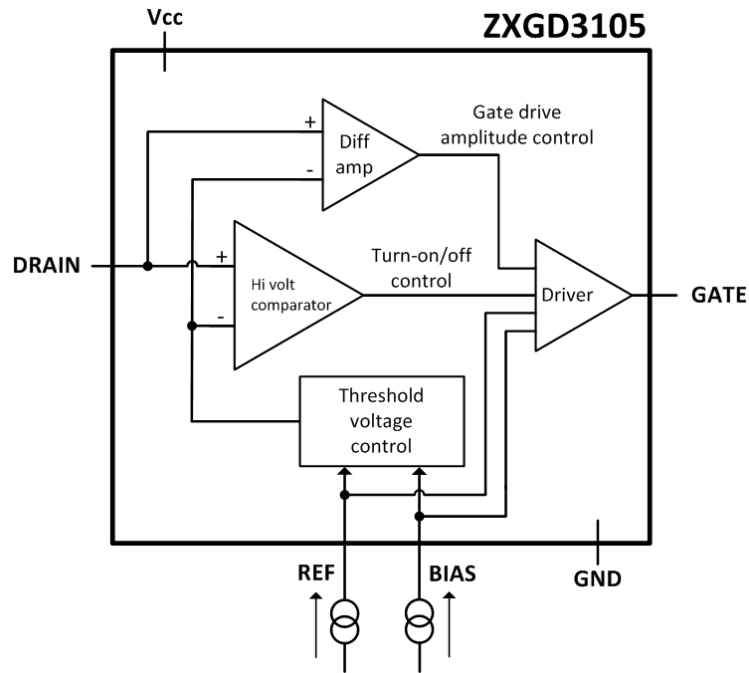

Pin Number	Pin Name	Description
1	V _{CC}	Power Supply This supply pin should be closely decoupled to ground with a ceramic capacitor.
2	DNC	Do Not Connect Leave pin floating.
3	BIAS	Bias Connect this pin to V _{CC} via R _{BIAS} resistor. Select R _{BIAS} to source 0.54mA into this pin. Refer to Table 1 and 2, in Application Information section.
4	DRAIN	Drain Sense Connect directly to the synchronous MOSFET drain terminal.
5	REF	Reference Connect this pin to V _{CC} via R _{REF} resistor. Select R _{REF} to source 1.02mA into this pin. Refer to Table 1 and 2, in Application Information section.
6	DNC	Do Not Connect Leave pin floating.
7	GND	Ground Connect this pin to the synchronous MOSFET source terminal and ground reference point.
8	GATE	Gate Drive This pin sinks and sources the I _{SINK} and I _{SOURCE} current to the synchronous MOSFET gate.

Maximum Ratings (@ $T_A = +25^\circ\text{C}$, unless otherwise specified.)

Characteristic	Symbol	Value	Unit
Supply Voltage, Relative to GND	V_{CC}	25	V
Drain Pin Voltage	V_D	-3 to +100	V
Gate output Voltage	V_G	-3 to $V_{CC} + 3$	V
Gate Driver Peak Source Current	I_{SOURCE}	4	A
Gate Driver Peak Sink Current	I_{SINK}	9	A
Reference Voltage	V_{REF}	V_{CC}	V
Reference Current	I_{REF}	25	mA
Bias Voltage	V_{BIAS}	V_{CC}	V
Bias Current	I_{BIAS}	100	mA

Thermal Characteristics (@ $T_A = +25^\circ\text{C}$, unless otherwise specified.)

Characteristic	Symbol	Value	Unit
Power Dissipation Linear Derating Factor	P_D	490	mW mW/ $^\circ\text{C}$
		3.92	
		655	
		5.24	
Thermal Resistance, Junction to Ambient	$R_{\theta JA}$	720	$^\circ\text{C/W}$
		5.76	
		785	
		6.28	
Thermal Resistance, Junction to Lead	$R_{\theta JL}$	255	$^\circ\text{C/W}$
		191	
		173	
		159	
Thermal Resistance, Junction to Case	$R_{\theta JC}$	45	$^\circ\text{C/W}$
Operating Temperature Range	T_J	-40 to +150	$^\circ\text{C}$
Storage Temperature Range	T_{STG}	-55 to +150	

ESD Ratings (Note 11)

Characteristic	Symbol	Value	Unit	JEDEC Class
Electrostatic Discharge - Human Body Model	ESD HBM	4,000	V	3A
Electrostatic Discharge - Machine Model	ESD MM	200	V	B

- Notes:
- For a device surface mounted on minimum recommended pad layout FR4 PCB with high coverage of single sided 1oz copper, in still air conditions; the device is measured when operating in a steady-state condition.
 - Same as Note (5), except pin 1 (V_{CC}) and pin 7 (GND) are both connected to separate 5mm x 5mm 1oz copper heatsinks.
 - Same as Note (6), except both heatsinks are 10mm x 10mm.
 - Same as Note (6), except both heatsinks are 15mm x 15mm.
 - Thermal resistance from junction to solder-point at the end of each lead on Pin 1 (V_{CC}) or Pin 7 (GND).
 - Thermal resistance from junction to top of the case.
 - Refer to JEDEC specification JESD22-A114 and JESD22-A115.

Thermal Derating Curve

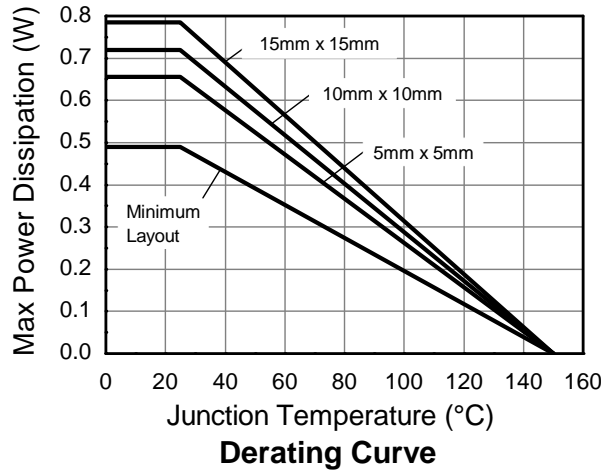

Electrical Characteristics (@ $T_A = +25^\circ\text{C}$, unless otherwise specified.)

$V_{CC} = 10\text{V}$; $R_{BIAS} = 18\text{k}\Omega$ ($I_{BIAS} = 0.54\text{mA}$); $R_{REF} = 9.1\text{k}\Omega$ ($I_{REF} = 1.02\text{mA}$)

Characteristic	Symbol	Min	Typ	Max	Unit	Test Condition
Input Supply						
Quiescent Current	I_Q	—	1.56	—	mA	$V_{DRAIN} \geq 0\text{mV}$
Gate Driver						
Gate Peak Source Current	I_{SOURCE}	—	1.2	—	A	Capacitive Load: $C_L = 10\text{nF}$
Gate Peak Sink Current	I_{SINK}	—	5	—		
Detector under DC condition						
Turn-Off Threshold Voltage	V_T	-20	-10	0	mV	$V_G = 1\text{V}$
Gate Output Voltage	$V_{G(off)}$	—	0.2	0.6	V	$V_{DRAIN} \geq 1\text{V}$
	V_G	5.0	7.8	—		$V_{DRAIN} = -50\text{mV}$
		8.0	9.4	—		$V_{DRAIN} = -100\text{mV}$
Switching Performance						
Turn-On Propagation Delay	$t_{d(rise)}$	—	118	—	nS	Capacitive Load: $C_L = 10\text{nF}$ Rise and Fall Measured 10% to 90%
Gate Rise Time	t_r	—	77	—		
Turn-Off Propagation Delay	$t_{d(fall)}$	—	14	—		
Gate Fall Time	t_f	—	26	—		

Test Circuit for Switching Performance

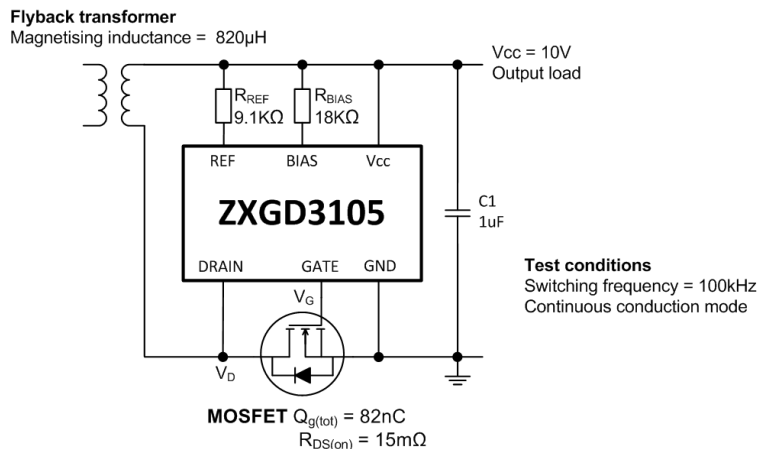

Typical Electrical Characteristics (@ $T_A = +25^\circ\text{C}$, unless otherwise specified.)

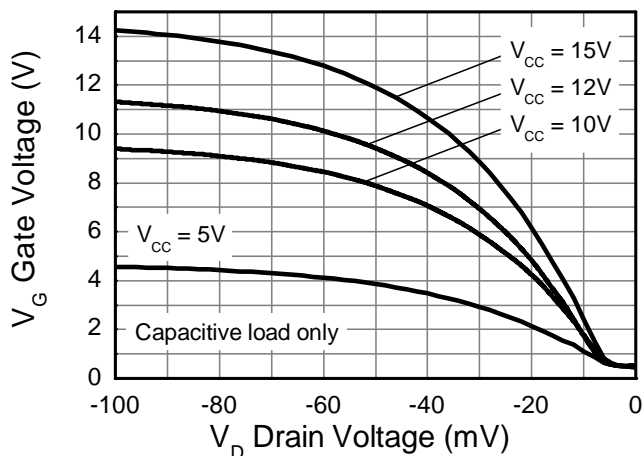

Transfer Characteristic

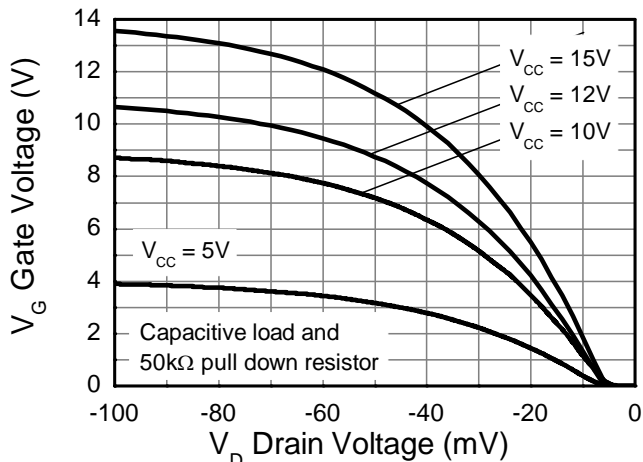

Transfer Characteristic

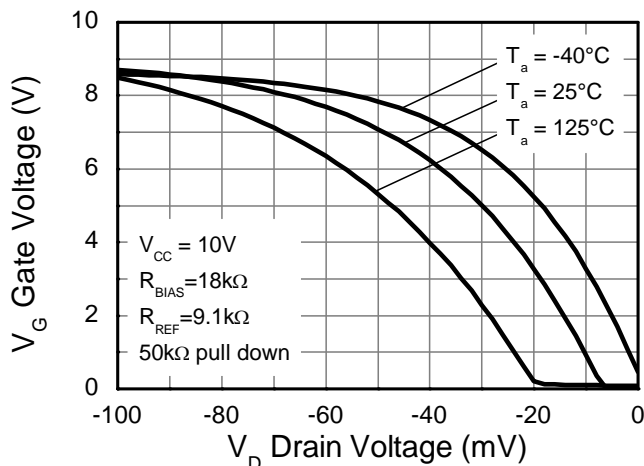

Transfer Characteristic

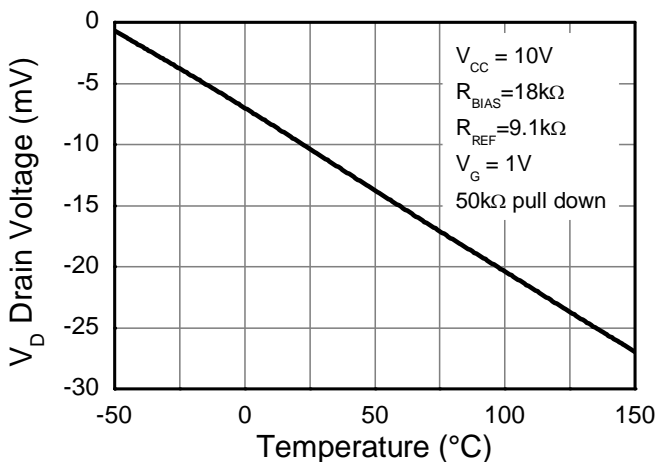

Drain Sense Voltage vs Temperature

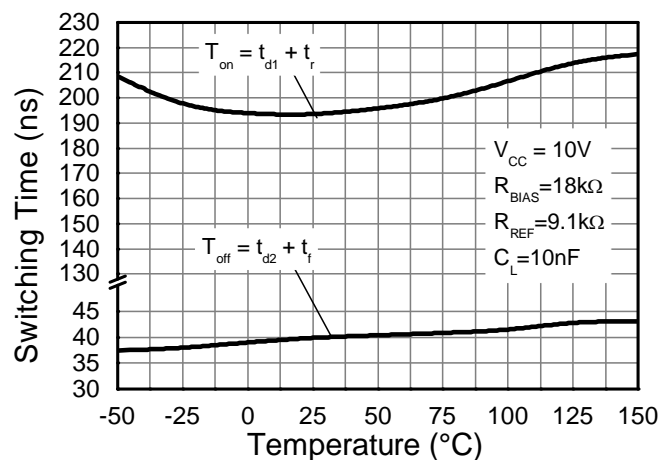

Switching vs Temperature

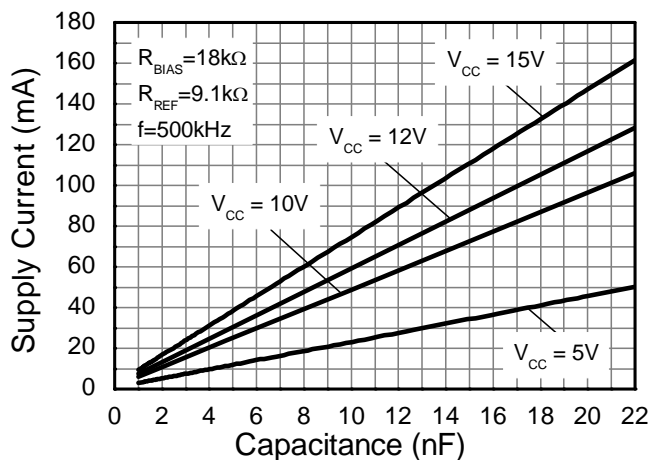

Supply Current vs Capacitive Load

Typical Electrical Characteristics (Continued) (@T_A = +25°C, unless otherwise specified.)

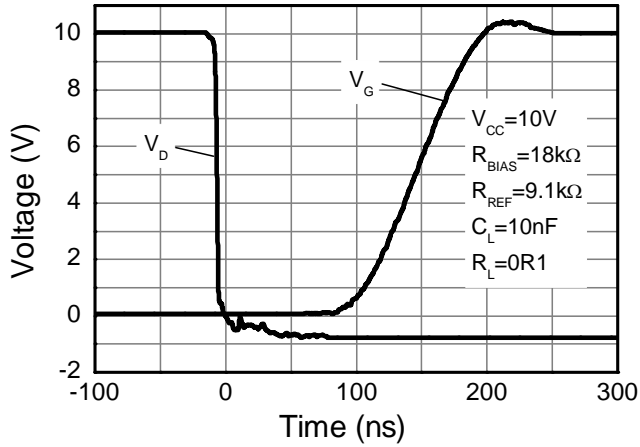

Switch On Speed

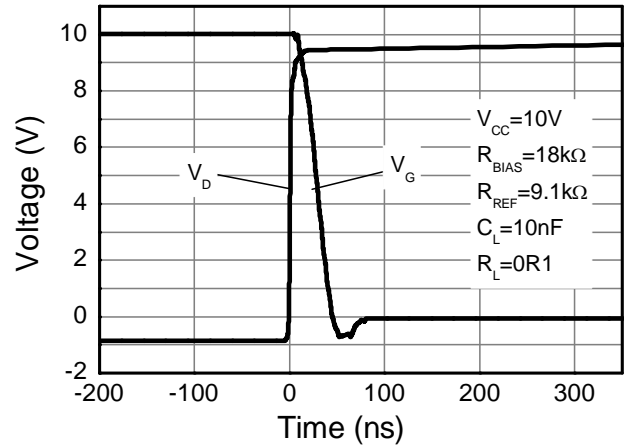

Switch Off Speed

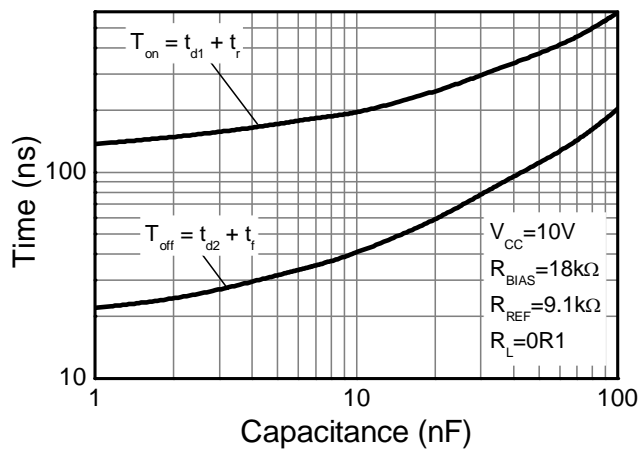

Switching vs Capacitive Load

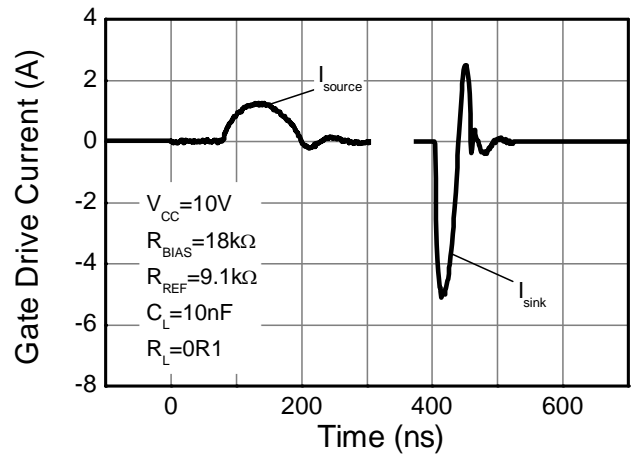

Gate Drive Current

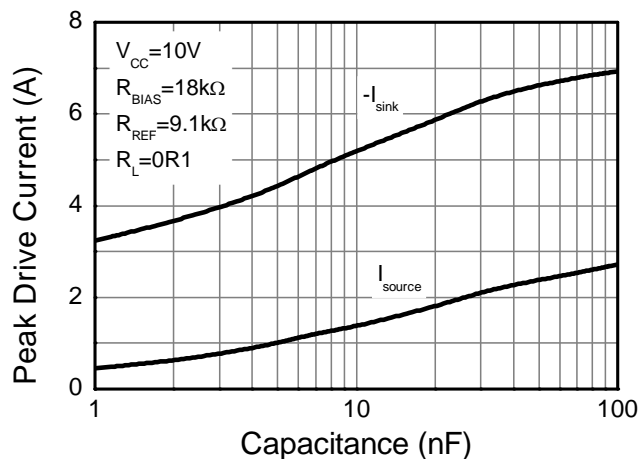

Gate Current vs Capacitive Load

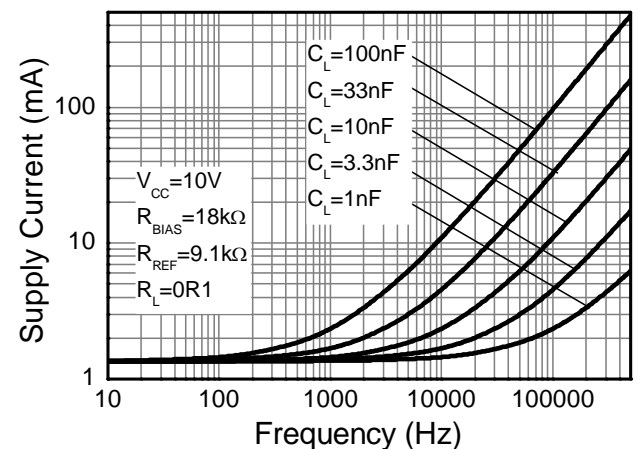

Supply Current vs Frequency

Application Information

The purpose of the ZXGD3105 is to drive a MOSFET as a low V_F Schottky diode replacement in isolated AC-DC converter. When combined with a low $R_{DS(ON)}$ MOSFET, the controller can yield significant power efficiency improvement, whilst maintaining design simplicity and incurring minimal component count. Figure 1 shows the typical configuration of ZXGD3105 for synchronous rectification in a low output voltage flyback converter.

A typical circuit configuration of synchronous rectification with ZXGD3105 for use in resonant converter is shown in Figure 2. Two ZXGD3105 together with two synchronous MOSFETs should be used on the secondary side of the center tapped transformer winding.

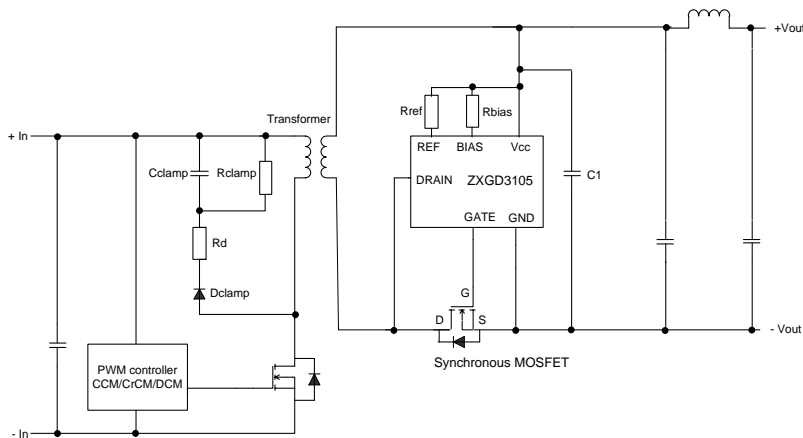

Figure 1 Typical Flyback Application Schematic

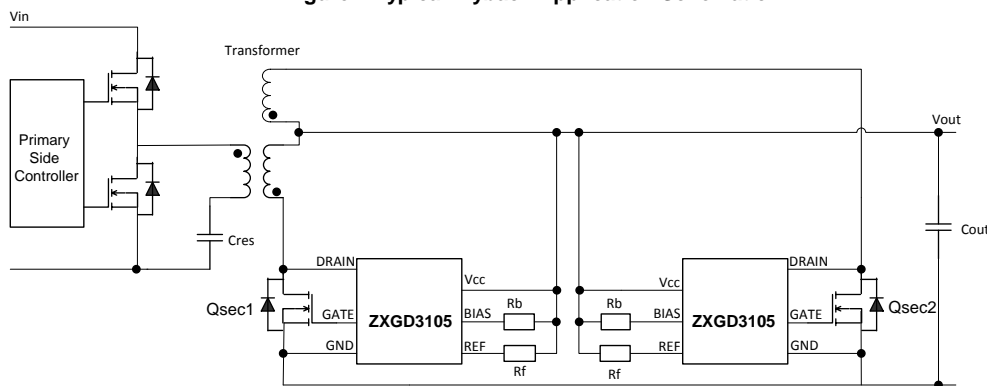

Figure 2 Synchronous Rectification in Resonant Converter

Threshold Voltage and Resistor Setting

The correct selection of external resistors R_{REF} and R_{BIAS} is important for optimum device operation. R_{REF} and R_{BIAS} supply fixed current into the I_{REF} and I_{BIAS} Pin of the controller. I_{REF} and I_{BIAS} combines to set the turn-off threshold voltage level, V_T . In order to set V_T to $-10mV$, the recommended I_{REF} and I_{BIAS} are $1.02mA$ and $0.54mA$ respectively.

The values for R_{REF} and R_{BIAS} are selected based on the V_{CC} voltage. If the V_{CC} Pin is connected to the power converter's output, the resistors should be selected based on the nominal converter's output voltage. Table 1 provides the recommended resistor values for different V_{CC} voltages.

Supply, V_{CC} (V)	Bias Resistor, R_{BIAS} (k Ω)	Reference Resistor, R_{REF} (k Ω)
5	9.6	4.3
10	18	9.1
12	24	11
15	30	15

Table 1 Recommended Resistor Values for Different V_{CC} Voltages

Application Information (Continued)

Functional Descriptions for Flyback Converter

The operation of the device is described step-by-step with reference to the timing diagram in Figure 3.

1. The detector stage monitors the MOSFET Drain-Source voltage.
2. When, due to transformer action, the MOSFET body diode is forced to conduct there is a negative voltage on the Drain Pin due to the body diode forward voltage.
3. As the negative Drain voltage crosses the turn-off threshold voltage (V_T), the detector stage outputs a positive voltage with respect to Ground after the turn-on delay time ($t_{d(fall)}$). This voltage is then fed to the MOSFET driver stage and current is sourced out of the Gate Pin.
4. The controller goes into proportional Gate drive control – the Gate output voltage is proportional to the MOSFET on-resistance-induced Drain-Source voltage. Proportional gate drive control ensures that the MOSFET conducts during the majority of the conduction cycle to minimize power loss in the body diode.
5. As the Drain current decays linearly toward zero, proportional gate drive control reduces the Gate voltage so the MOSFET can be turned off rapidly at zero current crossing. The Gate voltage falls to 1V when the Drain-Source voltage crosses the detection threshold voltage to minimize reverse current flow.
6. At zero Drain current, the controller Gate output voltage is pulled low to $V_{G(off)}$ to ensure that the MOSFET is off.

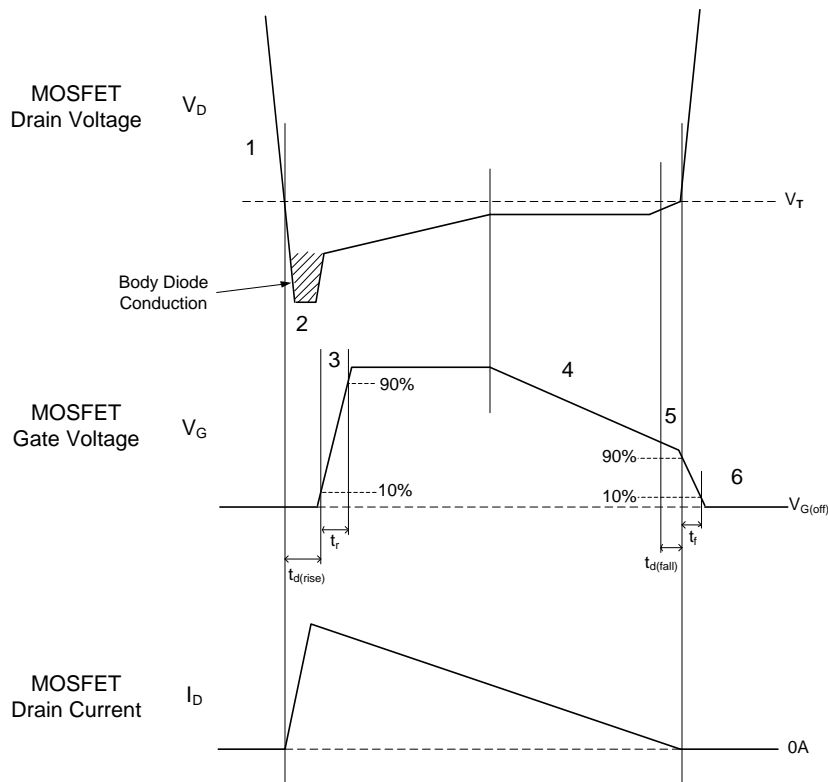

Figure 3 Timing Diagram for a Critical Conduction Mode Flyback Converter

Application Information (Cont.)

Functional Descriptions for Resonant Converter

The operation of the ZXGD3105 in resonant converter is described with reference to Figure 4.

1. The detector stage monitors the MOSFET Drain-GND voltage.
2. When the MOSFET body diode is forced to conduct, due to transformer action, there is a negative voltage on the Drain Pin due to the body diode forward voltage.
3. As the negative Drain voltage crosses the threshold voltage (V_T), the detector stage outputs a positive voltage with respect to Ground after the turn-on delay time ($t_{d(rise)}$). This voltage is then fed to the MOSFET driver stage and current is sourced out of the Gate pin.
4. The controller goes into proportional Gate drive control. The Gate voltage now varies according to the MOSFET's Drain-GND voltage. During this phase, the relationship of V_G vs. V_D is shown by the Transfer Characteristic Graph on Page 5 of this datasheet. As the Drain current decays linearly, the Gate voltage reduces so the MOSFET can be turned off rapidly at zero current crossing.

Proportional Gate drive control also ensures that the Gate voltage is supplied to the MOSFET Gate until the Drain current is virtually zero. This eliminates any parasitic diode conduction after the MOSFET switches off.

5. The Gate voltage falls to 1V when the Drain-GND voltage reaches V_T . The MOSFET is turned off precisely when the sinusoidal current goes to zero, with little or no reverse current. Threshold voltage (V_T) is defined as the Drain voltage V_D level, at which the Gate voltage V_G is 1V (refer to Electrical Characteristics Table on Page 4).
6. At zero Drain current, the Gate voltage is pulled low to $V_{G(off)}$ to ensure that the MOSFET is off.

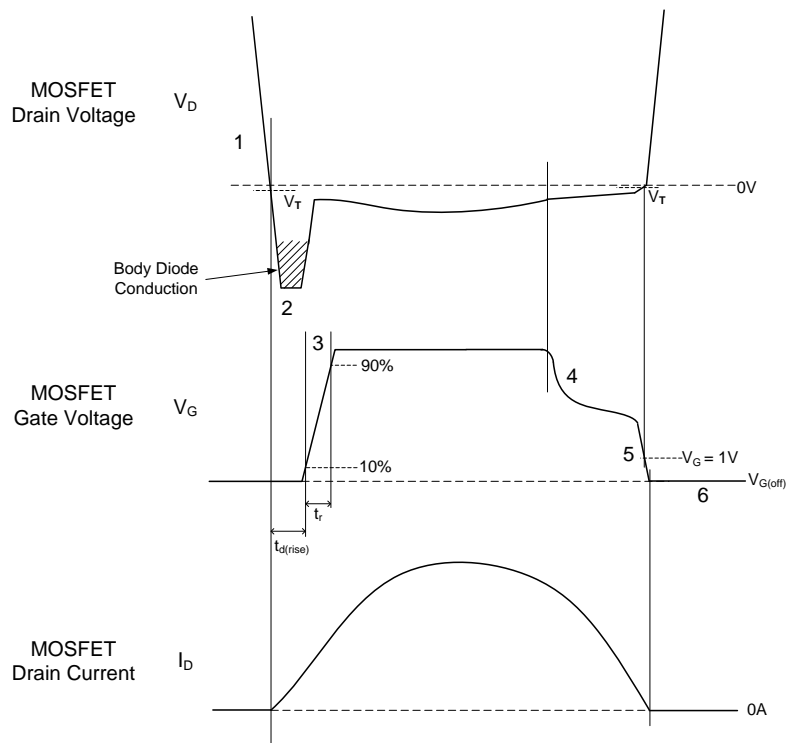

Figure 4 Timing Diagram of Synchronous Rectification in the Resonant Converter

Application Information (Cont.)

Besides that, Proportional Gate drive control improves the rectifier efficiency even at light to medium load condition by ensuring that the MOSFETs conduct during majority of the conduction cycle as shown in Figure 5a.

At reduced load condition, early termination of the Gate drive voltage is likely for digital-level Gate drive due to the low current, which means that the threshold V_T is breached. With the early termination of the Gate drive voltage, the MOSFET turns off and the body diode conducts, see Figure 5. This is shown by an increase in Drain-GND voltage for the remaining time of the current waveform. With the current flowing through the body diode there will be an increase in power developed within the MOSFET. The efficiency impact due to early termination of digital-level Gate driver increases with lower $R_{DS(ON)}$ MOSFET and/or higher operating frequency.

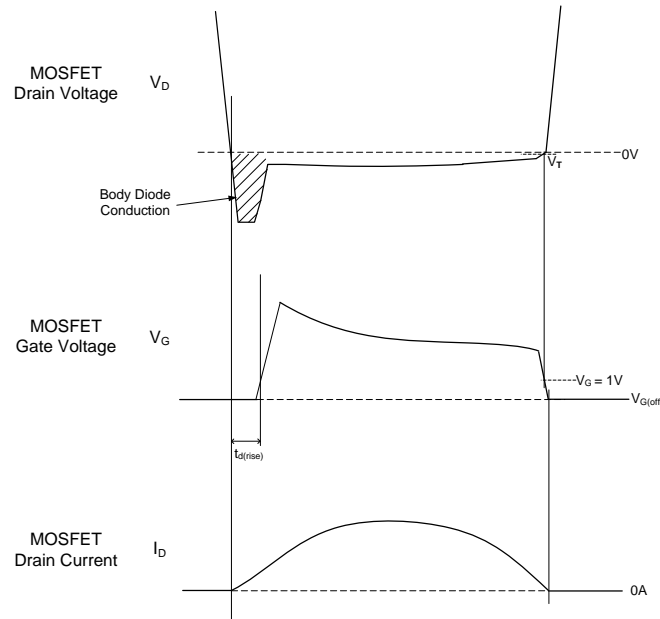
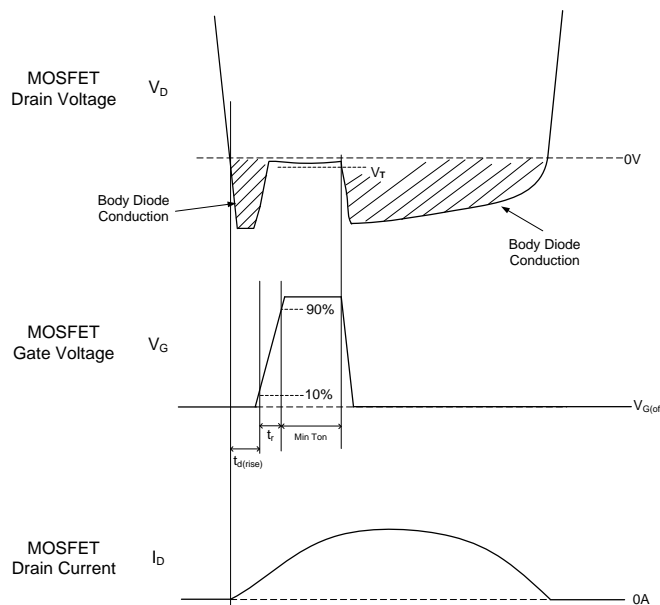

Figure 5 Timing Diagram of Synchronous Rectification in the Resonant Converter
(a) Proportional Gate Drive



(b) Digital-Level Gate Drive

Application Information (Cont.)

Gate Driver

The controller is provided with a single-channel, high-current Gate drive output, capable of driving one or more N-channel power MOSFETs. The controller can operate from V_{CC} of 4.5V to drive both standard MOSFETs and logic level MOSFETs.

The Gate Pins should be as close to the MOSFET's gate as possible. A resistor in series with the Gate Pin helps to control the rise time and decrease switching losses due to Gate voltage oscillation. A diode in parallel to the resistor is typically used to maintain fast discharge of the MOSFET's gate.

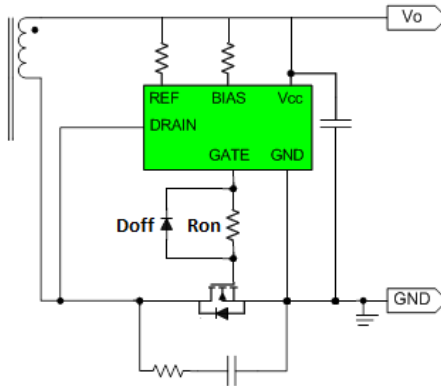

Figure 6 Typical Connection of the ZXGD3105 to the Synchronous MOSFET

Quiescent Current Consumption

The quiescent current consumption of the controller is the sum of I_{REF} and I_{BIAS} . For an application that requires ultra-low standby power consumption, I_{REF} and I_{BIAS} can be further reduced by increasing the value of resistor R_{REF} and R_{BIAS} .

Bias Current, I_{BIAS} (mA)	Ref Current, I_{REF} (mA)	Bias Resistor, R_{BIAS} (k Ω)	Ref Resistor, R_{REF} (k Ω)	Quiescent Current, I_q (mA)
0.25	0.61	39.2	15.4	0.86
0.35	0.81	28.0	11.5	1.16
0.46	0.99	21.5	9.3	1.45
0.50	1.00	19.6	8.9	1.50
0.55	1.13	17.8	8.1	1.68
0.80	1.66	12.1	5.6	2.46

Table 2 Quiescent Current Consumption for Different Resistor Values at $V_{CC} = 10V$

I_{REF} also controls the Gate driver peak sink current whilst I_{BIAS} controls the peak source current. At the default current value of I_{REF} and I_{BIAS} of 1.02mA and 0.54mA, the Gate driver is able to provide 2A source and 6A sink current. The Gate current decreases if I_{REF} and I_{BIAS} are reduced. Care must be taken in reducing the controller quiescent current so that sufficient drive current is still delivered to the MOSFET particularly for high switching frequency application.

Application Information (Cont.)

Layout Guidelines

When laying out the PCB, care must be taken in decoupling the ZXGD3105 closely to V_{CC} and Ground with 1μF low-ESR, low-ESL X7R type ceramic bypass capacitor. If the converter's output voltage is higher than 20V, a 12V zener diode should be connected from the Bias Pin to GND to clamp the Gate voltage and protect the synchronous MOSFET. Figure 7 shows the Typical Connection Diagram.

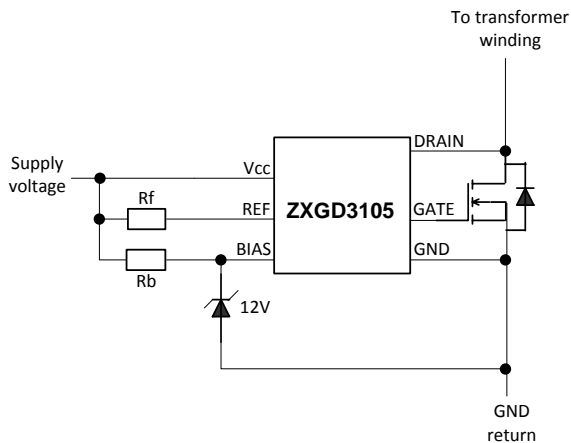

Figure 7 Zener Voltage Clamp Arrangement

GND is the Ground reference for the internal high voltage amplifier as well as the current return for the Gate driver. So the Ground return loop should be as short as possible. Sufficient PCB copper area should be allocated to the V_{CC} and GND Pin for heat dissipation especially for high switching frequency application.

Any stray inductance involved by the load current may cause distortion of the Drain-to-Source voltage waveform, leading to premature turn-off of the synchronous MOSFET. In order to avoid this issue, Drain voltage sensing should be done as physically close to the Drain terminals as possible. The PCB track length between the controller Drain Pin and the MOSFET's terminal should be kept less than 10mm. MOSFET packages with low internal wire bond inductance are preferred for high switching frequency power conversion to minimize body diode conduction.

After the primary MOSFET turns off, its Drain voltage oscillates due to reverse recovery of the snubber diode. These high frequency oscillations are reflected across the transformer to the Drain terminal of the synchronous MOSFET. The synchronous controller senses the Drain voltage ringing, causing its Gate output voltage to oscillate. The synchronous MOSFET cannot be fully enhanced until the Drain voltage stabilizes.

In order to prevent this issue, the oscillations on the primary MOSFET can be damped with either a series resistor R_D to the snubber diode or an R-C network across the diode (refer to Figure 8). Both methods reduce the oscillations by softening the snubber diode's reverse recovery characteristic.

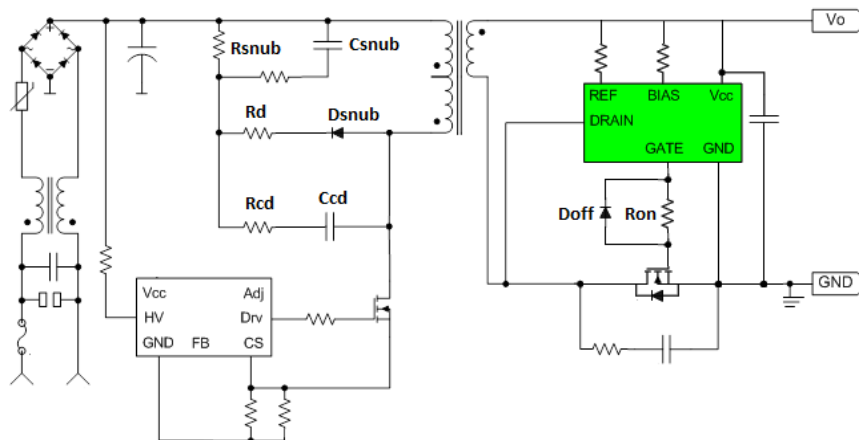
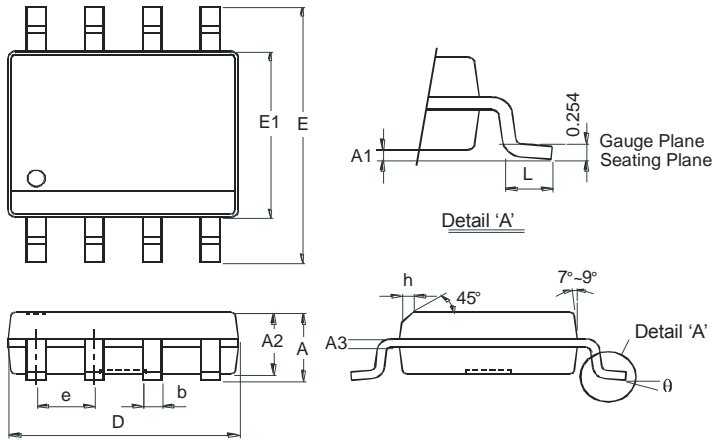

Figure 8 Primary Side Snubber Network to Reduce Drain Voltage Oscillations

Package Outline Dimensions

Please see AP02002 at <http://www.diodes.com/datasheets/ap02002.pdf> for the latest version.

SO-8



SO-8		
Dim	Min	Max
A	–	1.75
A1	0.10	0.20
A2	1.30	1.50
A3	0.15	0.25
b	0.3	0.5
D	4.85	4.95
E	5.90	6.10
E1	3.85	3.95
e	1.27 Typ	
h	–	0.35
L	0.62	0.82
θ	0°	8°
All Dimensions in mm		

Suggested Pad Layout

Please see AP02001 at <http://www.diodes.com/datasheets/ap02001.pdf> for the latest version.

SO-8

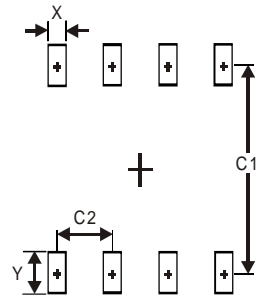

Dimensions	Value (in mm)
X	0.60
Y	1.55
C1	5.4
C2	1.27

IMPORTANT NOTICE

DIODES INCORPORATED MAKES NO WARRANTY OF ANY KIND, EXPRESS OR IMPLIED, WITH REGARDS TO THIS DOCUMENT, INCLUDING, BUT NOT LIMITED TO, THE IMPLIED WARRANTIES OF MERCHANTABILITY AND FITNESS FOR A PARTICULAR PURPOSE (AND THEIR EQUIVALENTS UNDER THE LAWS OF ANY JURISDICTION).

Diodes Incorporated and its subsidiaries reserve the right to make modifications, enhancements, improvements, corrections or other changes without further notice to this document and any product described herein. Diodes Incorporated does not assume any liability arising out of the application or use of this document or any product described herein; neither does Diodes Incorporated convey any license under its patent or trademark rights, nor the rights of others. Any Customer or user of this document or products described herein in such applications shall assume all risks of such use and will agree to hold Diodes Incorporated and all the companies whose products are represented on Diodes Incorporated website, harmless against all damages.

Diodes Incorporated does not warrant or accept any liability whatsoever in respect of any products purchased through unauthorized sales channel. Should Customers purchase or use Diodes Incorporated products for any unintended or unauthorized application, Customers shall indemnify and hold Diodes Incorporated and its representatives harmless against all claims, damages, expenses, and attorney fees arising out of, directly or indirectly, any claim of personal injury or death associated with such unintended or unauthorized application.

Products described herein may be covered by one or more United States, international or foreign patents pending. Product names and markings noted herein may also be covered by one or more United States, international or foreign trademarks.

This document is written in English but may be translated into multiple languages for reference. Only the English version of this document is the final and determinative format released by Diodes Incorporated.

LIFE SUPPORT

Diodes Incorporated products are specifically not authorized for use as critical components in life support devices or systems without the express written approval of the Chief Executive Officer of Diodes Incorporated. As used herein:

A. Life support devices or systems are devices or systems which:

1. are intended to implant into the body, or
2. support or sustain life and whose failure to perform when properly used in accordance with instructions for use provided in the labeling can be reasonably expected to result in significant injury to the user.

B. A critical component is any component in a life support device or system whose failure to perform can be reasonably expected to cause the failure of the life support device or to affect its safety or effectiveness.

Customers represent that they have all necessary expertise in the safety and regulatory ramifications of their life support devices or systems, and acknowledge and agree that they are solely responsible for all legal, regulatory and safety-related requirements concerning their products and any use of Diodes Incorporated products in such safety-critical, life support devices or systems, notwithstanding any devices- or systems-related information or support that may be provided by Diodes Incorporated. Further, Customers must fully indemnify Diodes Incorporated and its representatives against any damages arising out of the use of Diodes Incorporated products in such safety-critical, life support devices or systems.

Copyright © 2015, Diodes Incorporated

www.diodes.com