

	DESCRIPTION OF REVISIONS	BY	CHKD	DATE	COUNT	DESCRIPTION OF REVISIONS	BY	CHKD	DATE
△					△				
△					△				
APPLICABLE STANDARD									
RATING	OPERATING TEMPERATURE RANGE	- 3 5 °C TO 8 5 °C(NOTE1)			STORAGE TEMPERATURE RANGE	- 1 0 °C TO 6 0 °C			
	VOLTAGE	3 0 V A C			APPLICABLE CONNECTOR	DF30*-*DP-0.4V(**)			
	CURRENT	0.3 A							
SPECIFICATIONS									
ITEM		TEST METHOD			REQUIREMENTS			QT	AT
CONSTRUCTION									
GENERAL EXAMINATION		VISUALLY AND BY MEASURING INSTRUMENT.			ACCORDING TO DRAWING.			X	X
MARKING		CONFIRMED VISUALLY.						X	X
ELECTRICAL CHARACTERISTICS									
CONTACT RESISTANCE		1 0 0 mA (DC OR 1000 Hz).			1 0 0 mΩ MAX.			X	—
INSULATION RESISTANCE		1 0 0 V DC.			5 0 MΩ MIN.			X	—
VOLTAGE PROOF		1 0 0 V AC FOR 1 min.			NO FLASHOVER OR BREAKDOWN.			X	—
MECHANICAL CHARACTERISTICS									
MECHANICAL OPERATION		5 0 TIMES INSERTIONS AND EXTRACTIONS.			① CONTACT RESISTANCE: 1 0 0 mΩ MAX. ② NO DAMAGE, CRACK AND LOOSENESS, OF PARTS.			X	—
VIBRATION		FREQUENCY 1 0 TO 5 5 Hz, SINGLE AMPLITUDE 0.75 mm, 1 0 CYCLES OF EACH 3 AXIAL DIRECTION FOR 5 min.			① NO ELECTRICAL DISCONTINUITY OF 1 μs. ② NO DAMAGE, CRACK AND LOOSENESS, OF PARTS.			X	—
SHOCK		4 9 0 m/s ² DURATION OF PULSE 1 1 ms AT 3 TIMES FOR 3 DIRECTIONS.			① NO ELECTRICAL DISCONTINUITY OF 1 μs. ② NO DAMAGE, CRACK AND LOOSENESS, OF PARTS.			X	—
ENVIRONMENTAL CHARACTERISTICS									
DAMP HEAT (STEADY STATE)		EXPOSED AT 4 0 ± 2 °C, 9 0 TO 9 5 %, 9 6 h.			① CONTACT RESISTANCE: 1 0 0 mΩ MAX. ② INSULATION RESISTANCE: 2 5 MΩ MIN. ③ NO DAMAGE, CRACK AND LOOSENESS, OF PARTS.			X	—
RAPID CHANGE OF TEMPERATURE		TEMPERATURE -55→ 5 TO 35→85→ 5 TO 35 °C TIME 30→10 TO 15→30→10 TO 15 min UNDER 5 CYCLES.			① CONTACT RESISTANCE: 1 0 0 mΩ MAX. ② INSULATION RESISTANCE: 5 0 MΩ MIN. ③ NO DAMAGE, CRACK AND LOOSENESS, OF PARTS.			X	—
CORROSION SALT MIST		EXPOSED IN 5% SALT WATER SPRAY FOR 48 h. (TEST STANDARD:IEC60068)			① CONTACT RESISTANCE: 1 0 0 mΩ MAX. ② NO HEAVY CORROSION.			X	—
SULPHUR DIOXIDE		EXPOSED IN 25 PPM FOR 96h. (TEST STANDARD:IEC60068)			① CONTACT RESISTANCE: 1 0 0 mΩ MAX. ② NO HEAVY CORROSION.			X	—
REMARKS					DRAWN	DESIGNED	CHECKED	APPROVED	RELEASED
NOTE1: INCLUDE THE TEMPERATURE RISING BY CURRENT.					T. Nishi	K. Miderikawa	K. Kikuchi	T. Ota	
Unless otherwise specified, refer to IEC60512.					04.08.25	04.08.25	04.08.25	04.08.25	
Note QT: Qualification Test AT: Assurance Test X: Applicable Test									
HRS HIROSE ELECTRIC CO., LTD.				SPECIFICATION SHEET			PART NO. DF30FC-*DS-0.4V(82)		
CODE NO.(OLD)		DRAWING NO.			CODE NO.			1/1	
CL		ELC4-303556-03			CL684-*****-82				

FOR REFERENCE ONLY
Subject to change without notice

TO
□
□
□
□



COUNT	DESCRIPTION OF REVISIONS	BY	CHKD	DATE	COUNT	DESCRIPTION OF REVISIONS	BY	CHKD	DATE

RECOMMENDED PATTERN

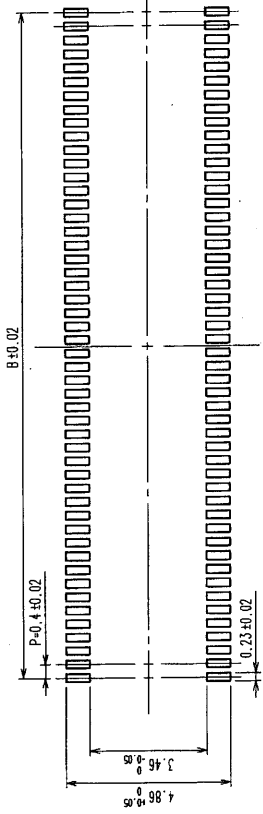
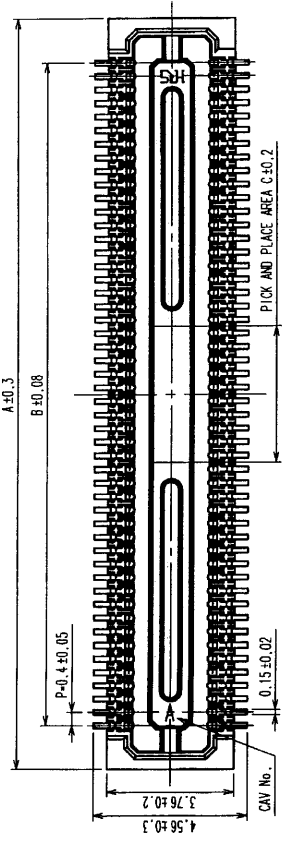

RECOMMENDED SOLDER PASTE: THICKNESS 120 μ m

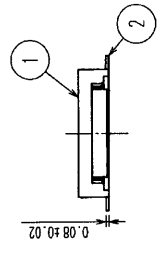

A-A(20:1)

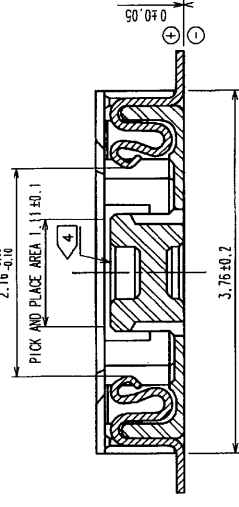

FOR REFERENCE ONLY
Subject to change without notice

PART NO.	CODE NO.	A	B	C
DF30FC-800S-0.4V(82)	CL684-1116-3-82	18.22	15.6	3.2
DF30FC-700S-0.4V(82)	CL684-1115-0-82	16.22	13.6	2.8
DF30FC-600S-0.4V(82)	CL684-1082-3-82	14.22	11.6	2.4
DF30FC-500S-0.4V(82)	CL684-1114-8-82	12.22	9.6	2
DF30FC-400S-0.4V(82)	CL684-1078-6-82	10.22	7.6	1.6
DF30FC-340S-0.4V(82)	CL684-1113-5-82	9.02	6.4	1.36
DF30FC-300S-0.4V(82)	CL684-1112-2-82	8.22	5.6	1.2
DF30FC-240S-0.4V(82)	CL684-1111-0-82	7.02	4.4	1.2
DF30FC-200S-0.4V(82)	CL684-1110-7-82	6.62	4.0	1.2
DF30FC-200S-0.4V(82)	CL684-1109-8-82	6.22	3.6	1.2

- NOTE 1. ALL LEADS CO-PLANARITY SHALL BE 0.1 MAX.
 2. PER REEL : 1000 CONNECTORS.
 3. AT THE BEGINNING OF THE REEL, 100 MM AT MIN SHALL BE EMPTY POCKETS.
 AT THE END OF THE REEL, 160 MM AT MIN SHALL BE EMPTY POCKETS.
 NO CAVITY ON THE CONNECTORS LESS THAN 24 POS.
 CONTACT PLATING : GOLD 0.05 μ m MIN.
 SMT LEAD : GOLD 0.02 μ m MIN.
 UNDERPLATING : NICKEL 1 μ m MIN.
 (SURFACE : SEALING)

2	PHOSPHOR BRONZE	5	4	POLYESTER	CLEAR(COVER TAPE)
1	LCP	UL94V-0. BLACK	3	PS	CLEAR(EMBOSSED CARRIER TAPE)
NO.	MATERIAL	FINISH, REMARKS	NO.	MATERIAL	FINISH, REMARKS
CODE NO. (OLD)	DESIGNED	CHECKED	APPROVED	RELEASING	
	T. NISHI	K. Nishikawa	J. Qao	8-25-74	
	04-08-25	04-08-25	04-08-25	USA	
DRAWING NO.	PART NO.				
EDC3-3035556-05	DF30FC-*DS-0.4V(82)				
SCALE FREE	CODE NO.				
UNITS mm	CL684-*****-82				

TO	
----	--

5	6	7	8
DESCRIPTION OF REVISIONS	BY	DATE	DATE

STYLE AND DIMENSION OF REEL (FREE)

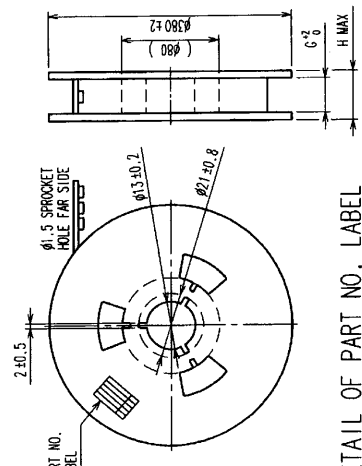

DETAIL OF PART NO. LABEL

SUPPLIER	
QUANTITY	
PART NO.	
CODE NO.	
DATE OF MANUFACTURE	
生産月日	年 月 日
圖書	CL684-*****-82
品名	DF30FC-DS-0.4V(82)
納入数量	1000個
納入者	ヒロセ電機(株)

PART NO.	D	E	F	G	H
DF30FC-80DS-0.4V(82)	CL684-1116-3-82	32	28.4	14.2	32.4 38.4
DF30FC-70DS-0.4V(82)	CL684-1115-0-82	24	-	11.5	24.4 30.4
DF30FC-60DS-0.4V(82)	CL684-1082-3-82	24	-	11.5	24.4 30.4
DF30FC-50DS-0.4V(82)	CL684-1114-8-82	24	-	11.5	24.4 30.4
DF30FC-40DS-0.4V(82)	CL684-1078-6-82	24	-	11.5	24.4 30.4
DF30FC-34DS-0.4V(82)	CL684-1113-5-82	16	-	7.5	16.4 22.4
DF30FC-30DS-0.4V(82)	CL684-1112-2-82	16	-	7.5	16.4 22.4
DF30FC-24DS-0.4V(82)	CL684-1111-0-82	16	-	7.5	16.4 22.4
DF30FC-22DS-0.4V(82)	CL684-1110-7-82	16	-	7.5	16.4 22.4
DF30FC-20DS-0.4V(82)	CL684-1109-8-82	16	-	7.5	16.4 22.4

B-B

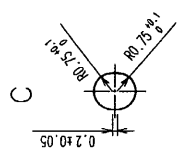
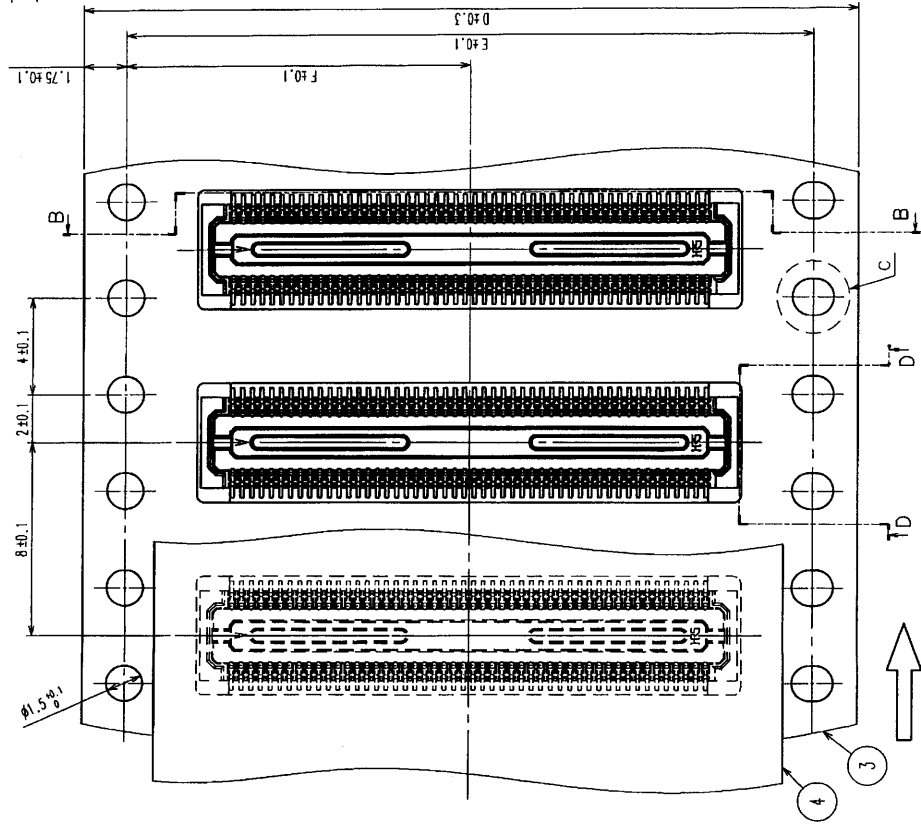
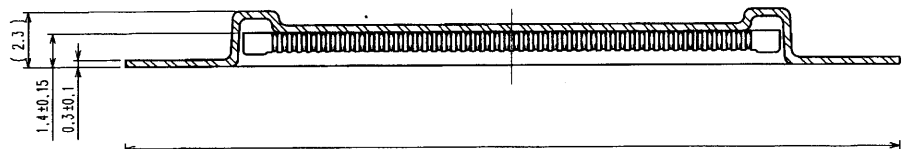

D-D

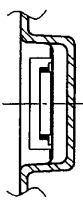

↑
DIRECTION OF UNREELING

CODE NO. (OLD)

FOR REFERENCE ONLY
Subject to change without notice

SCALE 5 : 1
UNITS mm

DRAWING NO. EDC3-303556-05
DRAWN T. NISHI
CHECKED K. MACHIMARU
DESIGNED K. MACHIMARU
DATE 04-08-25

PART NO. DF30FC-DS-0.4V(82)
CODE NO. CL684-*****-82

RELEASED
8-25-84
GCA

APPROVED J. C. ...
DATE 04-08-25

1		2			3			4		
COUNT	DESCRIPTION OF REVISIONS	BY	CHKD	DATE	COUNT	DESCRIPTION OF REVISIONS	BY	CHKD	DATE	
△					△					
△					△					
△					△					

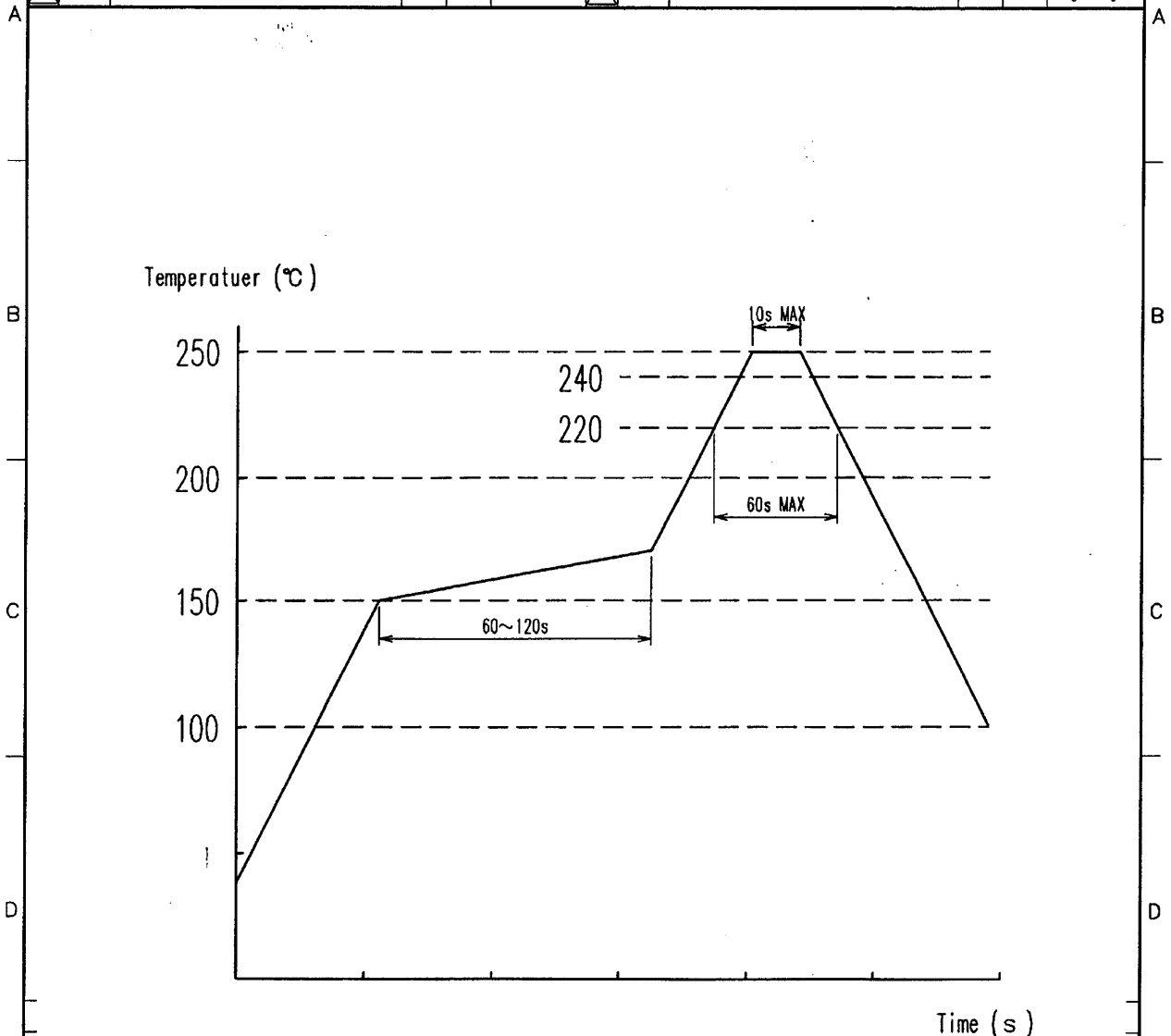

FOR REFERENCE ONLY
Subject to change without notice

NOTE 1. REFLOW SYSTEM : IR REFLOW (AIR OR N₂ GAS)
2. PERFORMING REFLOW : TWICE MAX

NO.	MATERIAL	FINISH, REMARKS	NO.	MATERIAL	FINISH, REMARKS
CODE NO. (OLD)			DRAWN	DESIGNED	CHECKED
			T. NISHI	W. Fukuchi	J. Tomita
			03.08.19	03.08.19	03.08.20
					APPROVED
					J. Ama
					03.08.20
					RELEASED
					HRS 8.25.04 USA
SCALE	DRAWING NO.	PART NO.			
FREE	EDC4-830116	DF30-*DS/DP-0.4V			
UNITS	DRAWING NO.	PART NO.			
mm	HRS HIROSE ELECTRIC CO., LTD.	CL684			
			1		
			1		

TO

1

2

3

4

FORM NO. 228



1	2	3	4						
COUNT	DESCRIPTION OF REVISIONS	BY	CHKD	DATE	COUNT	DESCRIPTION OF REVISIONS	BY	CHKD	DATE
△ 2	RE-H-06137	K.M.	J	'04.03.17	△				.
△					△				.
△					△				.

■ NOTES WHEN MATING DF30 SERIES CONNECTORS. △

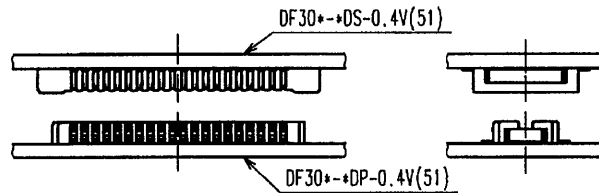

FIGURE-1

PLEASE LOCATE EACH CONNECTOR IN PARALLEL WHEN YOU PUT THEM IN MATING POSITION.

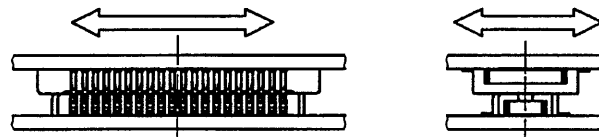

FIGURE-2

THE INSULATOR WILL BE DAMAGED AND THE CONTACTS WILL BE DEFORMED IF THE CONNECTORS ARE LOCATED INCLINED AND MATED BY EXCESSIVE FORCE.

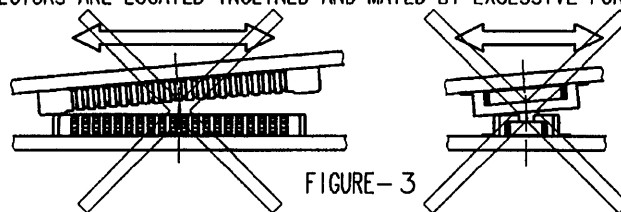

FIGURE-3

WHEN YOU LOCATE TWO CONNECTORS IN A PROPER POSITION, THEY WILL GO DOWN SLIGHTLY AT A LOWER LEVEL AND YOU WILL FIND THAT THEY GET LOCATED CORRECTLY. PLEASE MATE EACH CONNECTOR IN PARALLEL AFTER YOU CONFIRMED THAT THEY GO DOWN LOWER TO SOME EXTENT.

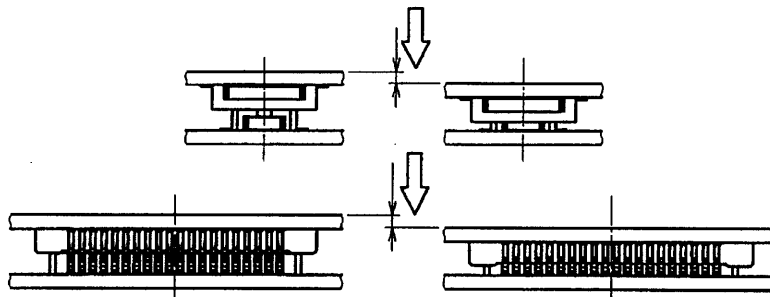

FIGURE-4

CODE NO. (OLD)		DRAWN	DESIGNED	CHECKED	APPROVED	RELEASED
		K.Midorikawa	K.Midorikawa	S.Tomioka	T.Oma	
NOTES WHEN MATING		'03.05.22	'03.05.22	'03.05.24	'03.05.24	
 SCALE FREE : 1 UNITS mm	DRAWING NO. EDSC4-830097		PART NO. DF30 Series △			
	 HIROSE ELECTRIC CO., LTD.		CODE NO. CL684		1/1	

TO

1	2				3				4				
COUNT	DESCRIPTION OF REVISIONS			BY	CHKD	DATE	COUNT	DESCRIPTION OF REVISIONS			BY	CHKD	DATE
4	RE-H-05956			K.M	S.T	'03.12.09							. .
1	RE-H-06137			K.M	S.T	'04.03.17							. .
													. .

■ NOTES WHEN EXTRACTING

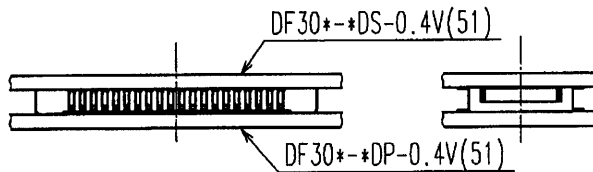

FIGURE-1

WHEN YOU EXTRACT CONNECTORS, PLEASE EXTRACT IN PARALLEL.

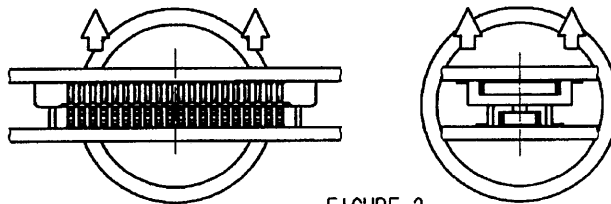

FIGURE-2



IF YOU'RE UNABLE TO EXTRACT IN PARALLEL DUE TO SET STRUCTURE OR SPACE, PLEASE EXTRACT AS FIGURE-3 (IN LONGER DIMENSION). PLEASE BE CAREFUL NOT TO DAMAGE CONTACTS AT SIDES, WHERE STRESS IS LIKELY TO GATHER WHEN CONNECTORS ARE MOUNTED ON SOFT FPC.

ESPECIALLY, PLEASE DO NOT EXTRACT FROM THE CORNER AS FIGURE-4. IT GIVES CRITICAL STRESS TO THE CONTACTS ON THE CROSS CORNER.

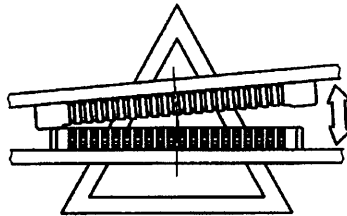

FIGURE-3

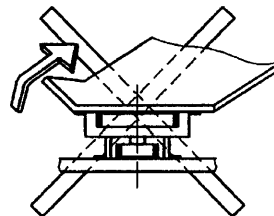

FIGURE-4



PLEASE DO NOT EXTRACT AS FIGURE-5. THE STRESS CONCENTRATES ON ONE ROW, AND MIGHT DAMAGE CONNECTORS TO MALFUNCTION.

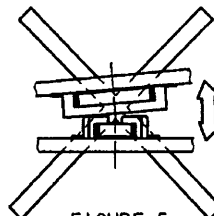

FIGURE-5

TO

CODE NO. (OLD)		DRAWN	DESIGNED	CHECKED	APPROVED	RELEASED
NOTES WHEN EXTRACTING		K.Midorikawa '03.11.13	K.Midorikawa '03.11.13	S.Tomioka '03.11.13	T.Oma '03.11.13	
DRAWING NO. EDSC4-830126		PART NO. DF30 Series				
SCALE FREE : 1		CODE NO. CL684				1/1
UNITS mm		HRS HIROSE ELECTRIC CO., LTD.				